

模組化並列式虎鉗系列 **Modular Clamping System**

本目錄內並列式虎鉗及自定心虎鉗均申請
有中國、美國、德國、日本專利在案,仿冒必究

專業製造**精密**機床配件

全方位**展**售您要的產品

One-Stop Shop

Professional Manufacturer of Grinding & Milling
Machine Accessories, Mold & Die Components.

Precision Machinery Accessories Series

MKS

模組化並列式虎鉗應用實例

Modular Clamping System Applications

用於立柱(可選搭虎鉗應用)

依立柱尺寸不同可自行選擇適合的虎鉗

Tombstone application: choose appropriate MKS model according to processing needs.

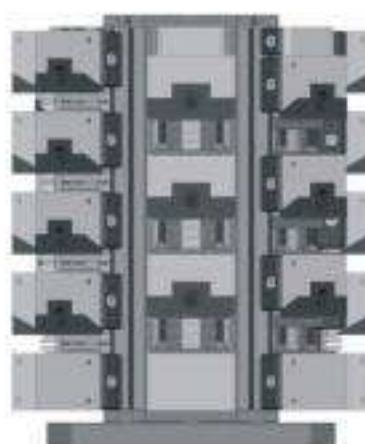
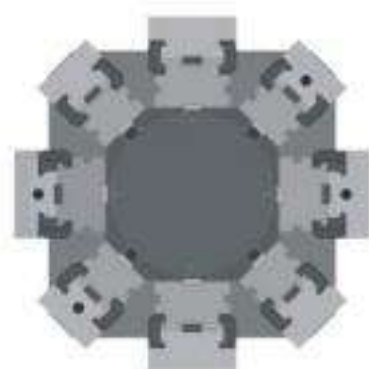

用於第四軸(可選搭虎鉗應用)

依第四軸分度盤中心高不同可自行調整虎鉗夾持的高度

4th-axis rotary table application: depending on the centre height of the index plate choosing the appropriate MKS model.

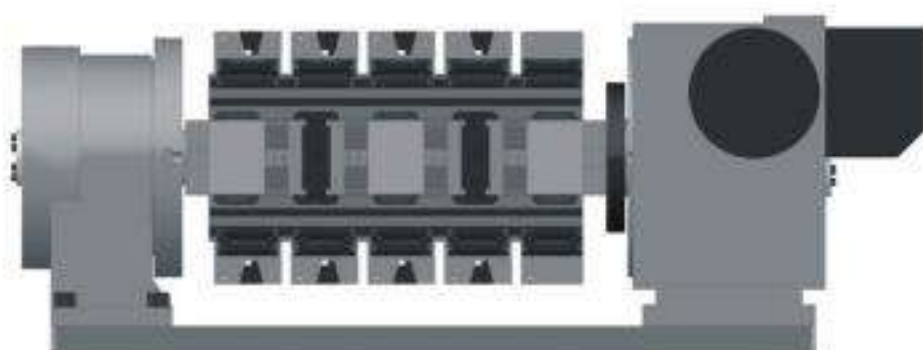

MKS

模組化並列式虎鉗應用實例

Modular Clamping System Applications

虎鉗搭配3"三爪夾頭(運用於60寬的基座上)
With optional 3" 3-Jaw Chuck(on 60mm wide base)



虎鉗搭配4"三爪夾頭(運用於80寬的基座上)  **C12**
With optional 4" 3-Jaw Chuck(on 80mm wide base)



虎鉗搭配5"三爪夾頭(運用於100寬的基座上)  **C12**
With optional 5" 3-Jaw Chuck(on 100mm wide base)

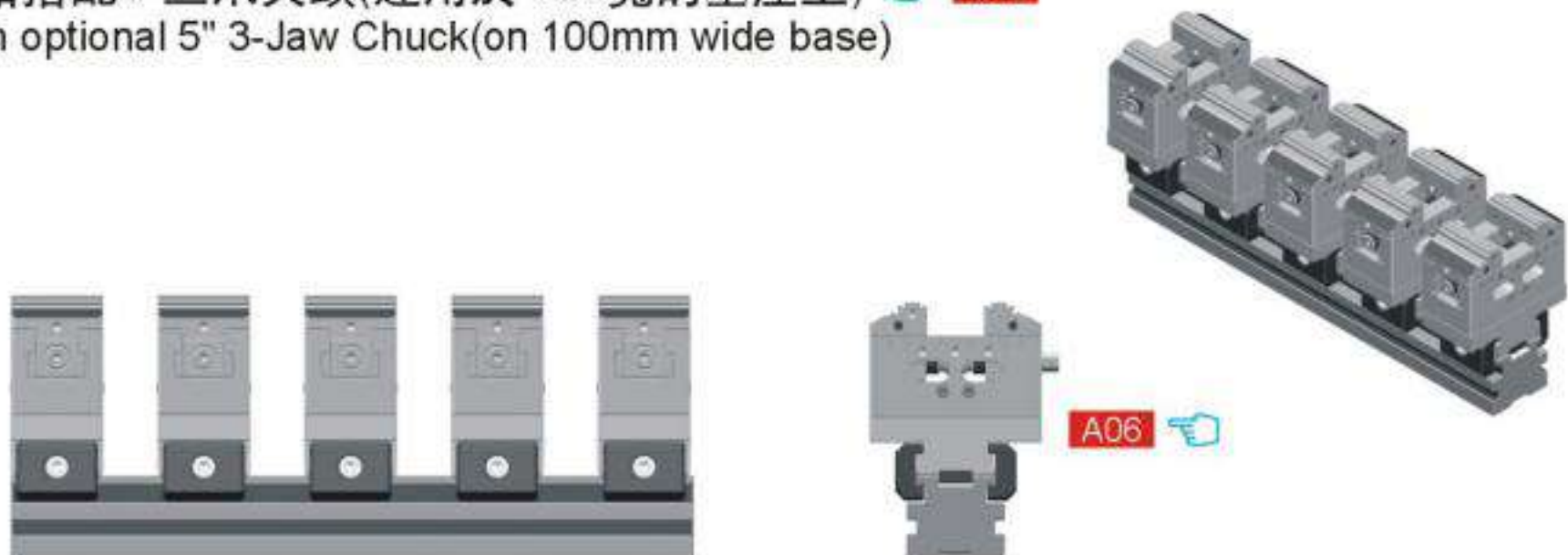

虎鉗搭配精密快速求心虎鉗(虎鉗基座透過連接板可用於60寬的基座)  **C12**
With optional self-centering vise on flanges (on 60mm wide base)



MKS-A / MKS-B

模組化並列式虎鉗應用實例 Modular Clamping System Applications

MKS-A(單向平行夾持)
(One side lockdown)

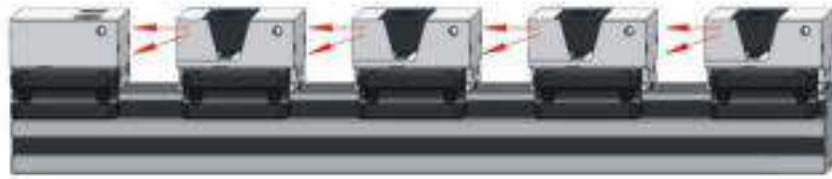

MKS-B(雙向平行夾持)
(Dual sides lockdown)

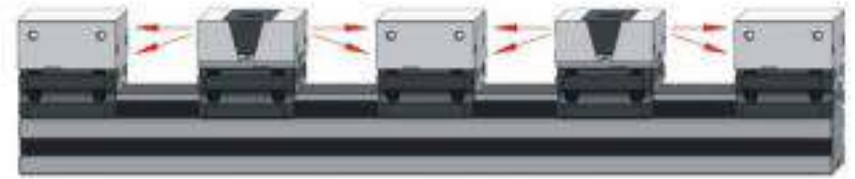

(MKS型適用於立式機床)
(on vertical machining center applications)

詳細請參閱 Refer to Page

C05、C07

MKS-A



等距夾持 Equidistant clamping

MKS-B

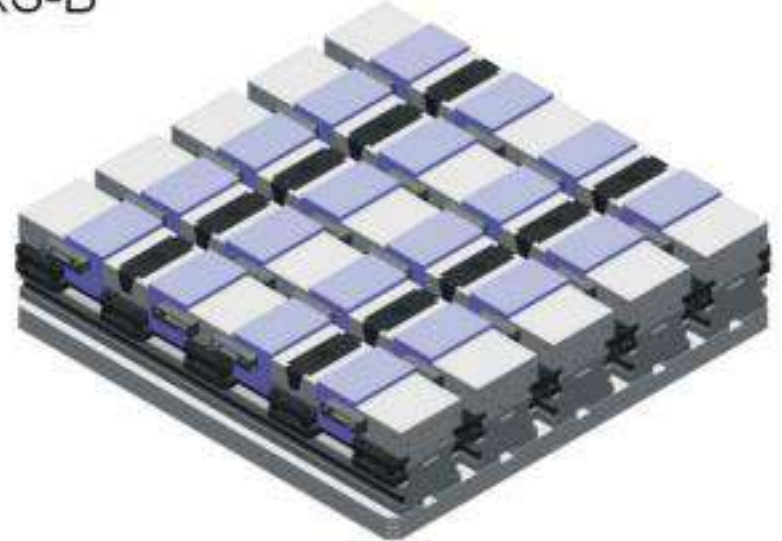

等距夾持 Equidistant clamping

MKS-A



不等距夾持 Not equidistant clamping

MKS-B

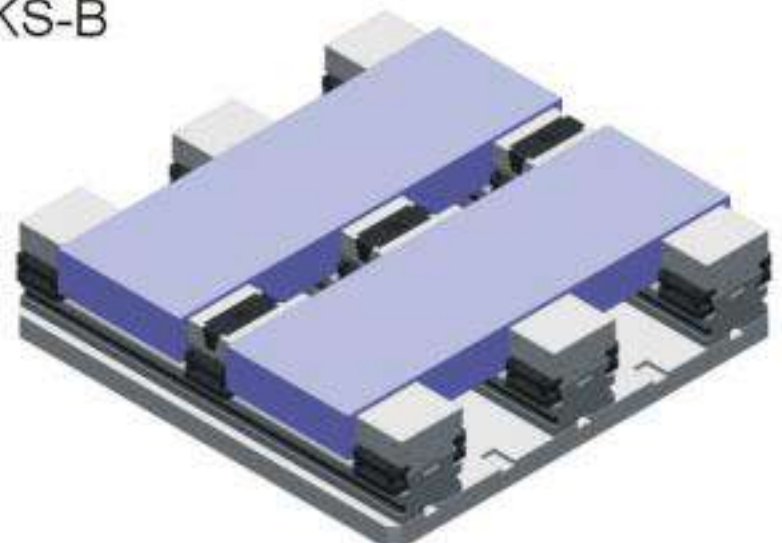

不等距夾持 Not equidistant clamping

MKS-A



搭配V型鉗口 with V clamp.

MKS-B

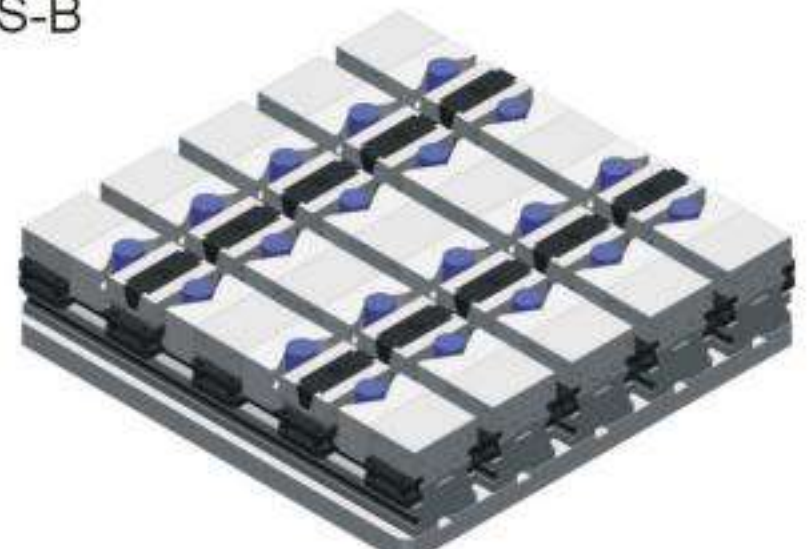

搭配V型鉗口 with V clamp.

MKS-A / MKS-B

模組化並列式虎鉗應用實例

Modular Clamping System Applications

MKS-A(單向平行夾持)
(One side lockdown)

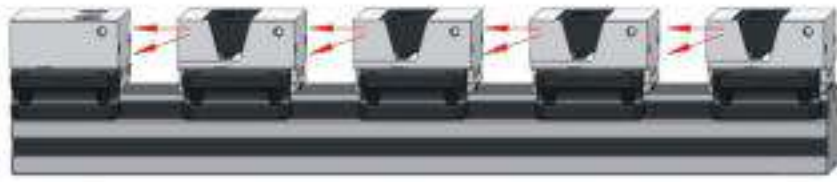

MKS-B(雙向平行夾持)
(Dual sides lockdown)



(MKS型亦適用於卧式機床)
on horizontal machining center applications:

詳細請參閱 Refer to Page

 C05、C07

MKS-A

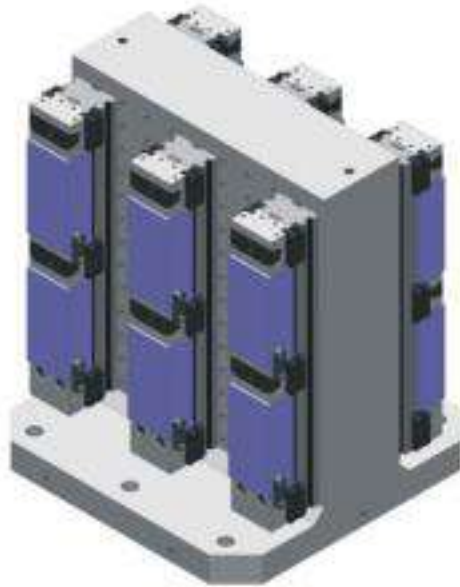

MKS-B



MKS-A

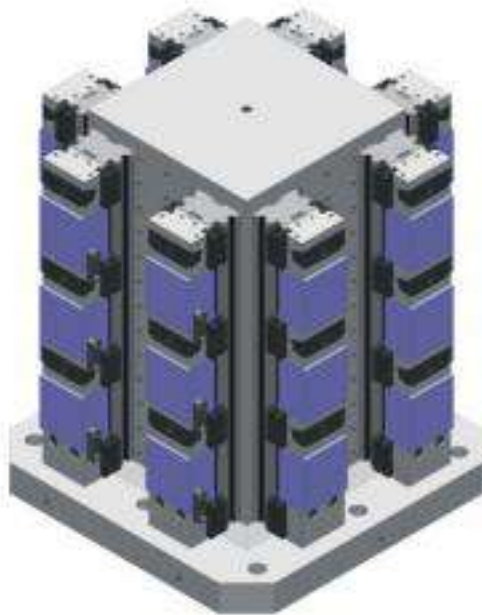

MKS-B



MKS-A

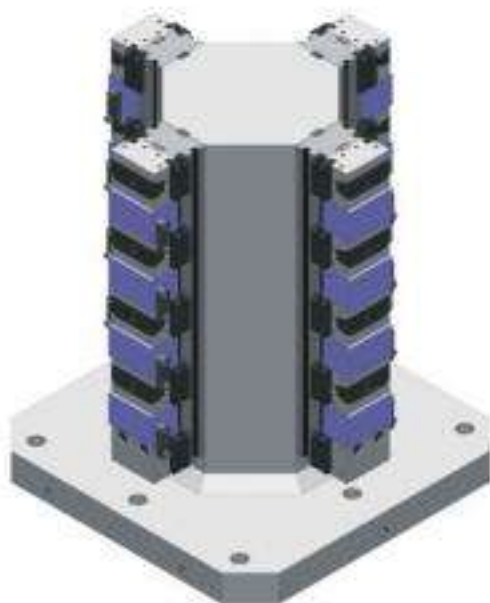

MKS-B

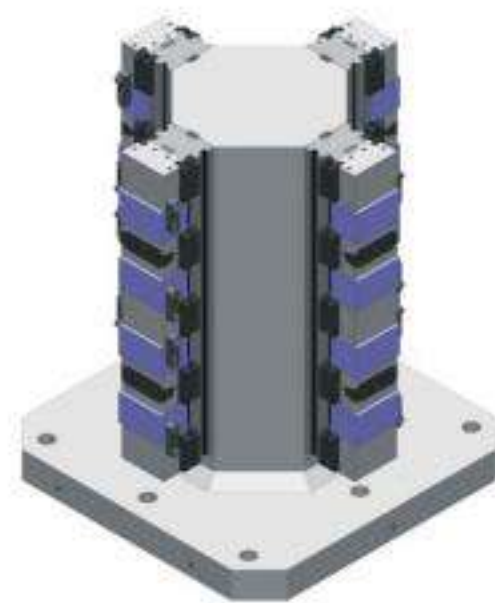

MKS-A / MKS-B

模組化並列式虎鉗 Modular Clamping System

MKS-A 單向平行夾持系列 One side lockdown

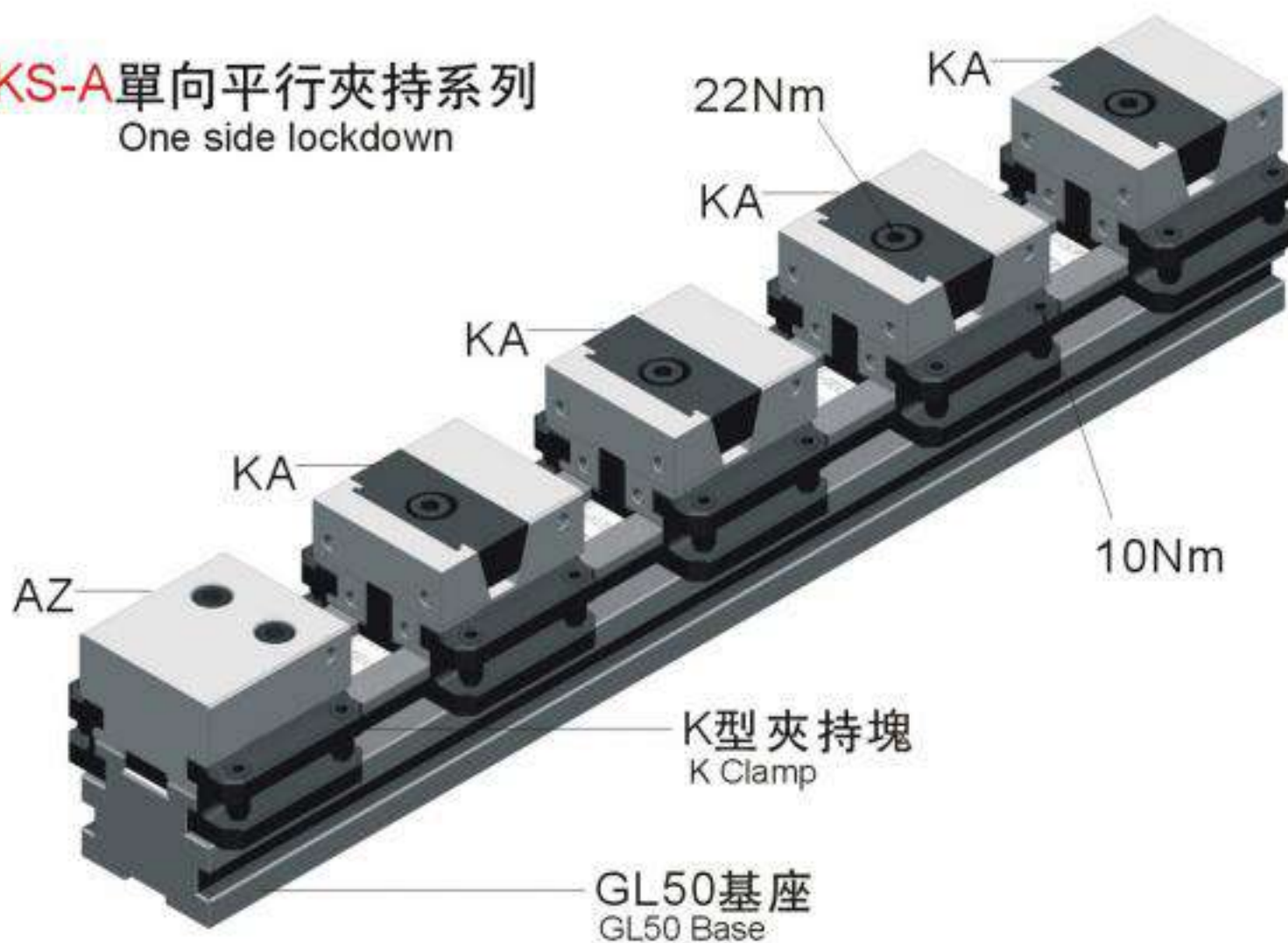

MKS-B 雙向平行夾持系列 Dual side lockdown

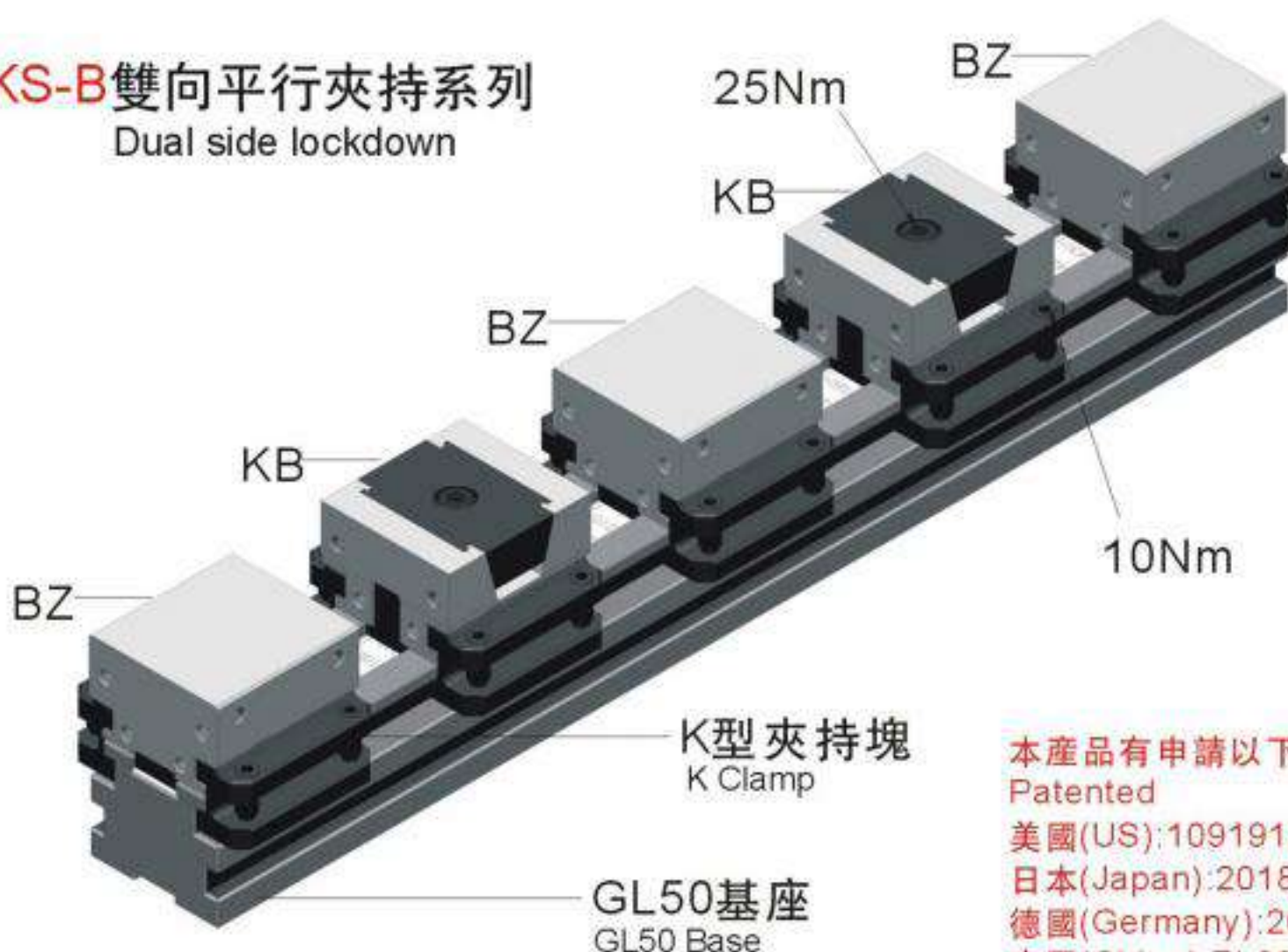

本產品有申請以下專利：
Patented

美國(US): 10919128

日本(Japan): 2018-004513

德國(Germany): 202018106562

中國(China): ZL201821863903.2

PAT: M572813

MKS-A / MKS-B

分解示意圖 Part diagram

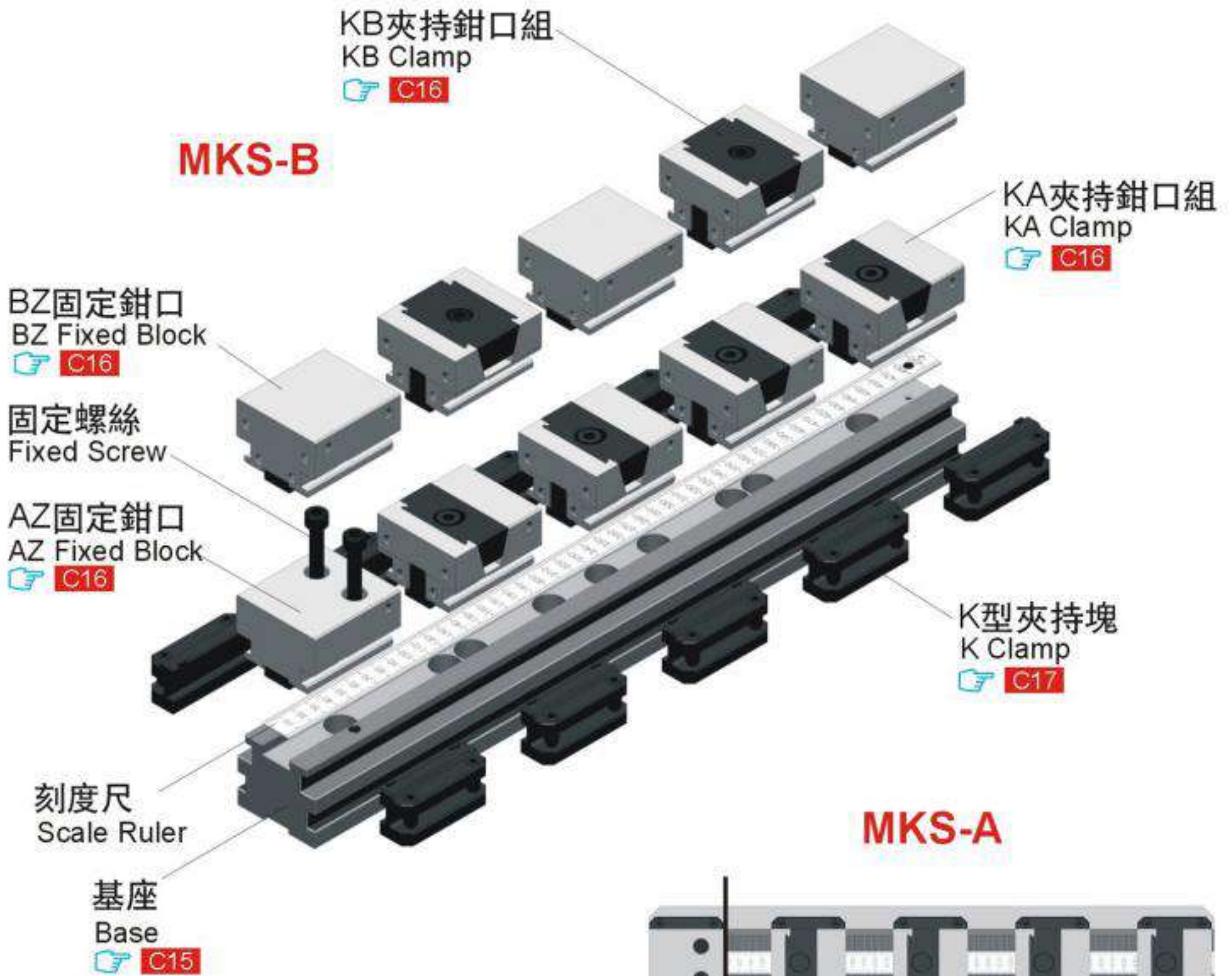

基本使用 Setting up

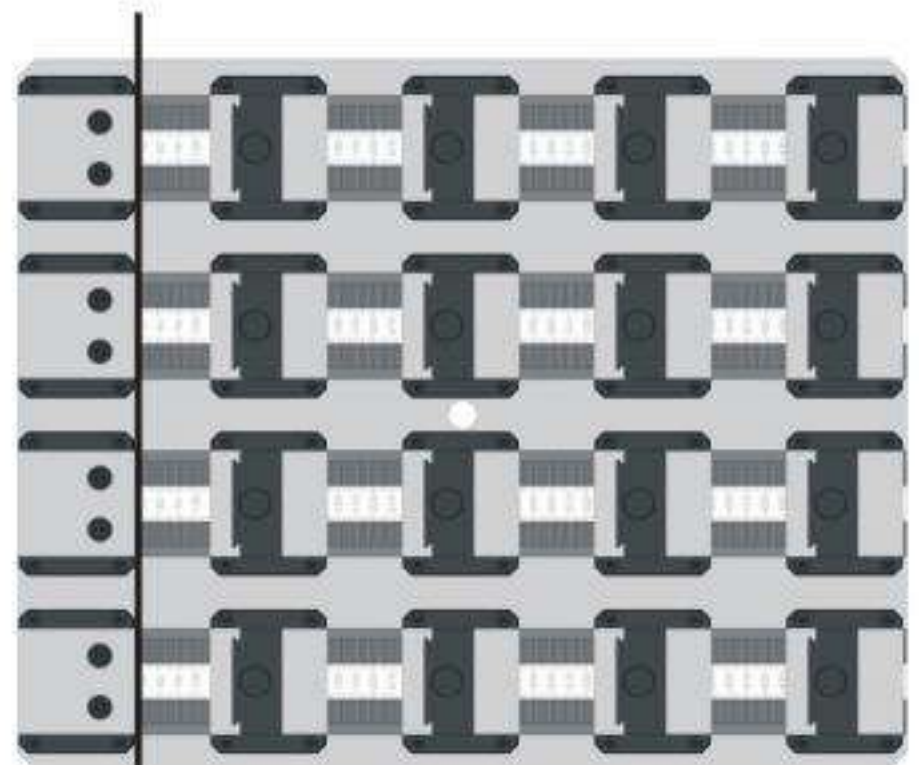

固定座鉗口於同一平面上
Alignment parallel setup.



基座垂直於機台
Alignment with perpendicularity setup.

MKS-A

模組化並列式虎鉗

Modular Clamping System

MKS-A單向平行夾持系列 One side lockdown

MKS-A=GL50+AZ+KAx4

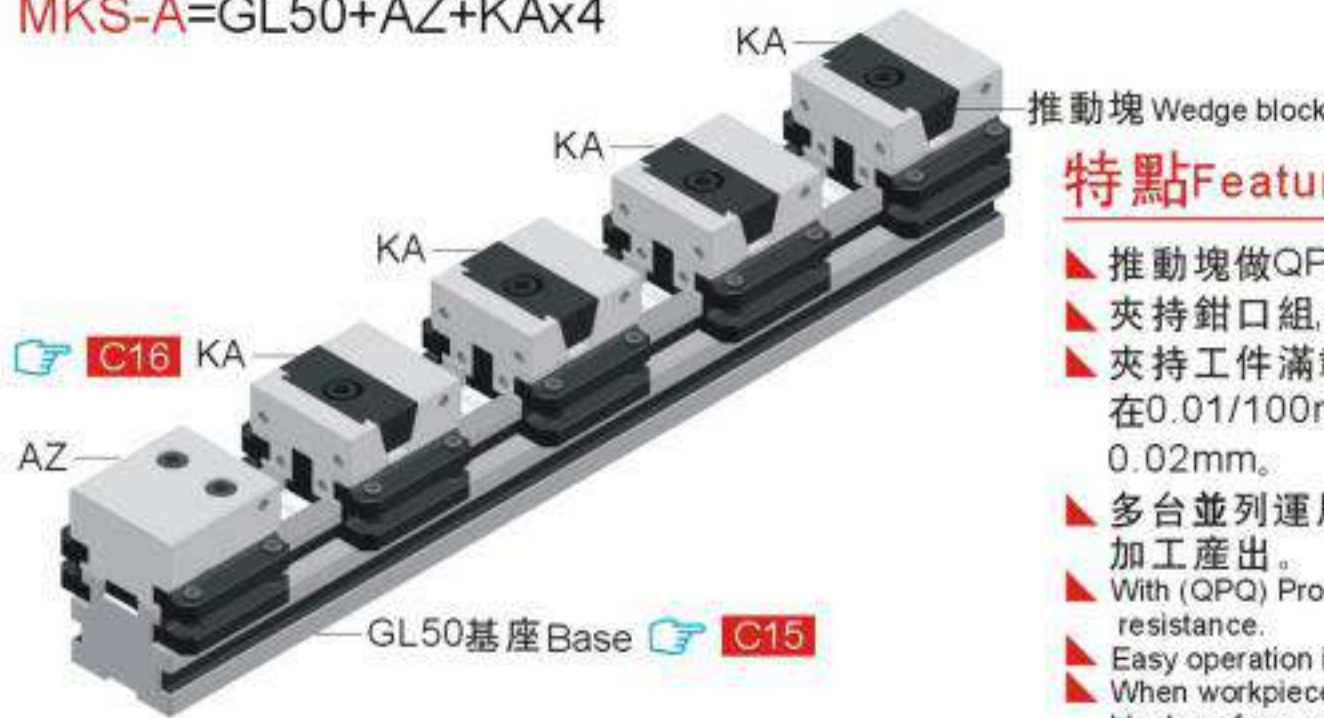

Tool steel **M** 工具鋼

H HRC48°~50°

F 2000kgf

特點Features:

- ▶ 推動塊做QPQ處理,耐用度高。
- ▶ 夾持鉗口組,拆裝簡單,位移方便,容易清潔。
- ▶ 夾持工件滿載時,上浮量以及垂直度精度保持在0.01/100mm內。工件夾持未滿載時上浮0.02mm。
- ▶ 多台並列運用於機床上夾持工作,可做到量加工產出。
- ▶ With (QPQ) Process on clamping block increasing wear-resistance.
- ▶ Easy operation increasing efficiency.
- ▶ When workpiece is fully clamped and contact with clamping block surface, accuracy remain within 0.01/100mm, not fully float up 0.02mm.
- ▶ Mass production by applying multiple parallel-use.

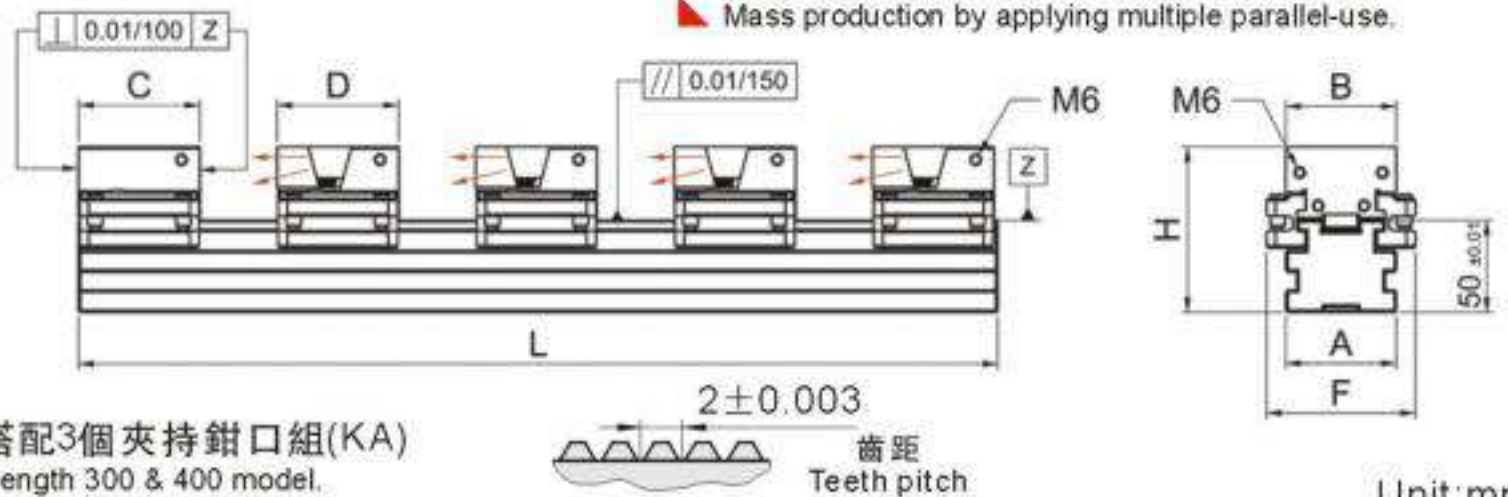

※ 基座300和400長,只搭配3個夾持鉗口組(KA)

※: Only KA x 3pcs included in length 300 & 400 model.

Unit:mm

訂購編號 Order No.	型號 Model	L	A	B	C	D	F	H	N.W.(kg)
64000A-300	MKS-A-048300	300※							10.87
64000A-400	MKS-A-048400	400※							12.77
64000A-500	MKS-A-048500	500	60	48	66	66	81	90	16.07
64000A-600	MKS-A-048600	600							17.86
64000A-700	MKS-A-048700	700							19.81
64002A-300	MKS-A-060300	300※							11.48
64002A-400	MKS-A-060400	400※							13.37
64002A-500	MKS-A-060500	500	60	60	66	66	81	90	16.83
64002A-600	MKS-A-060600	600							18.62
64002A-700	MKS-A-060700	700							20.57
64004A-400	MKS-A-080400	400※							19.33
64004A-500	MKS-A-080500	500							24.33
64004A-600	MKS-A-080600	600	80	80	66	72	99	95	26.97
64004A-700	MKS-A-080700	700							29.56
64004A-800	MKS-A-080800	800							32.19
64006A-400	MKS-A-100400	400※							24.51
64006A-500	MKS-A-100500	500							30.80
64006A-600	MKS-A-100600	600	100	100	66	72	119	95	34.23
64006A-700	MKS-A-100700	700							37.61
64006A-800	MKS-A-100800	800							41.05

MKS-A

夾持示意圖 Clamping Range Demo



推動塊高於鉗口座
是錯誤使用方式

推動塊低於鉗口座
是正確使用方式

Unit:mm

型號 Model	一個工件 1 workpiece	二個工件 2 workpiece	三個工件 3 workpiece	四個工件 4 workpiece
MKS-A-048300	168	50	12	--
MKS-A-048400	268	100	44	16
MKS-A-048500	368	150	78	42
MKS-A-048600	468	200	112	66
MKS-A-048700	568	250	144	92
MKS-A-060300	168	50	12	--
MKS-A-060400	268	100	44	16
MKS-A-060500	368	150	78	42
MKS-A-060600	468	200	112	66
MKS-A-060700	568	250	144	92
MKS-A-080400	268	100	44	16
MKS-A-080500	368	150	78	42
MKS-A-080600	468	200	112	66
MKS-A-080700	568	250	144	92
MKS-A-080800	668	300	178	116
MKS-A-100400	268	100	44	16
MKS-A-100500	368	150	78	42
MKS-A-100600	468	200	112	66
MKS-A-100700	568	250	144	92
MKS-A-100800	668	300	178	116
型號 Model	五個工件 5 workpiece	六個工件 6 workpiece	七個工件 7 workpiece	八個工件 8 workpiece
MKS-A-048300	--	--	--	--
MKS-A-048400	--	--	--	--
MKS-A-048500	20	6	--	--
MKS-A-048600	40	22	10	--
MKS-A-048700	60	38	24	12
MKS-A-060300	--	--	--	--
MKS-A-060400	--	--	--	--
MKS-A-060500	20	6	--	--
MKS-A-060600	40	22	10	--
MKS-A-060700	60	38	24	12
MKS-A-080400	--	--	--	--
MKS-A-080500	20	6	--	--
MKS-A-080600	40	22	10	--
MKS-A-080700	60	38	24	12
MKS-A-080800	80	56	38	24
MKS-A-100400	--	--	--	--
MKS-A-100500	20	6	--	--
MKS-A-100600	40	22	10	--
MKS-A-100700	60	38	24	12
MKS-A-100800	80	56	38	24

MKS-B 模組化並列式虎鉗

Modular Clamping System

MKS-B雙向平行夾持系列 Dual side lockdown

MKS-B=GL50+BZx3+KBx2

Tool steel **M** 工具鋼

H HRC48°~50°

F 2000kgf

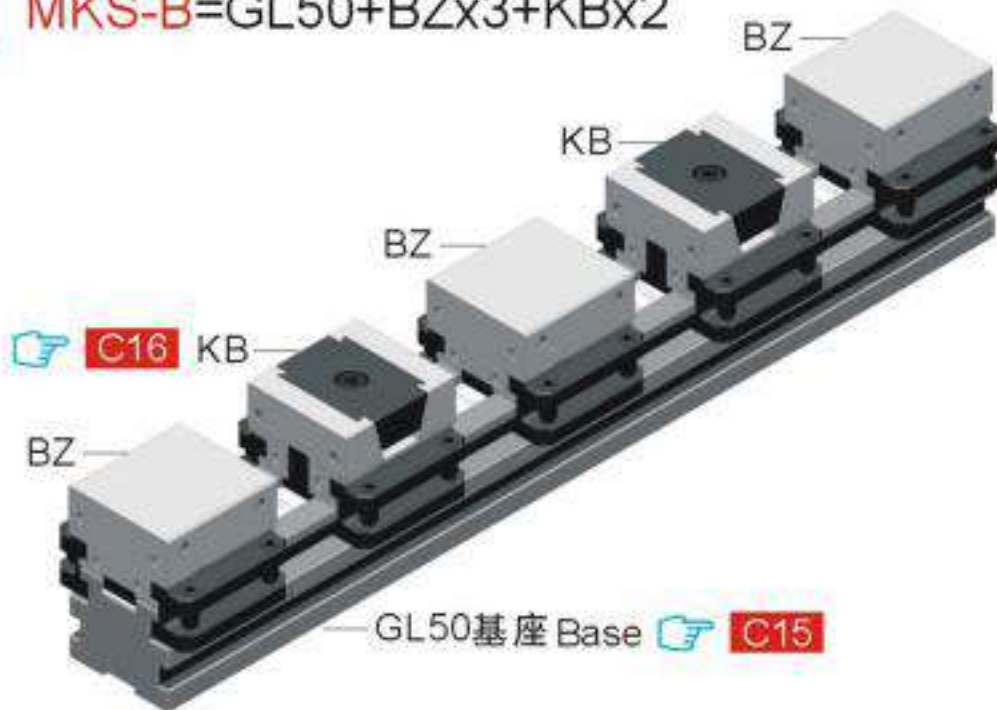

特點Features:

- ▶ 推動塊做QPQ處理,耐用度高。
- ▶ 夾持鉗口組,拆裝簡單,位移方便,容易清潔。
- ▶ 夾持工件滿載時,上浮量以及垂直度精度保持在0.01/100mm內。工件夾持未滿載時上浮0.02mm。
- ▶ 多台並列運用於機床上夾持工作,可做到量加工產出。
- ▶ With (QPQ) Process on clamping block increasing wear-resistance.
- ▶ Easy operation increasing efficiency.
- ▶ When workpiece is fully clamped and contact with clamping block surface, accuracy remain within 0.01/100mm, not fully float up 0.02mm.
- ▶ Mass production by applying multiple parallel-use.

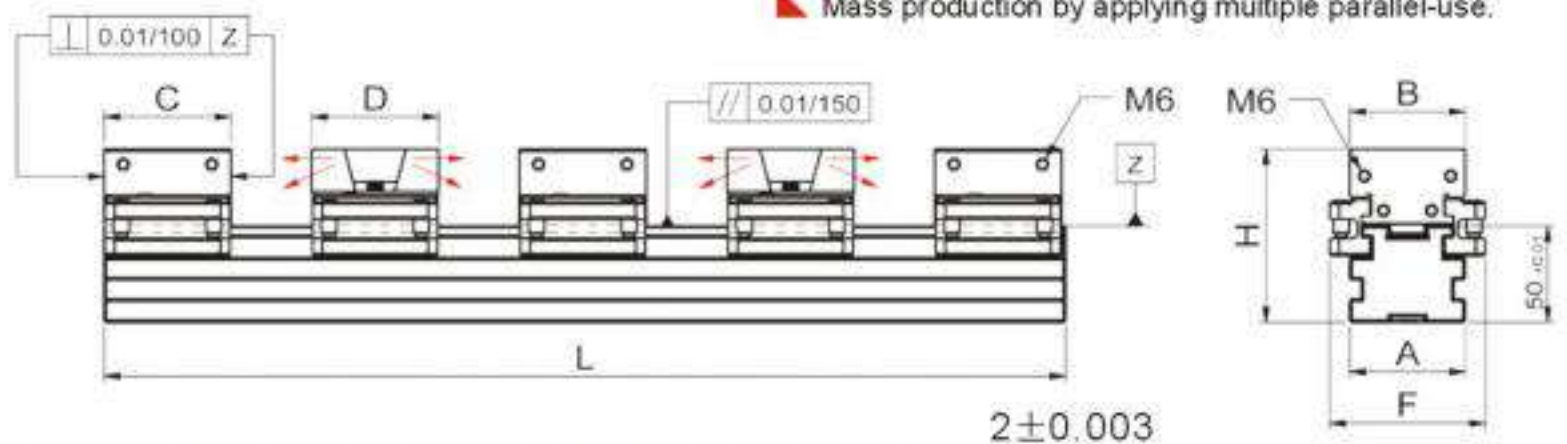

※ 基座300長,只搭配1個夾持鉗口組(KB)以及2個固定鉗口組(BZ)

※: Only KB x 1pc and BZ x 2pcs included in length 300 MKS-B model.



Unit:mm

訂購編號 Order No.	型號 Model	L	A	B	C	D	F	H	N.W.(kg)
64008B-300	MKS-B-048300	300※	60	48	50	50	81	90	8.59
64008B-400	MKS-B-048400	400							13.58
64008B-500	MKS-B-048500	500							14.50
64008B-600	MKS-B-048600	600							16.29
64008B-700	MKS-B-048700	700							18.25
64010B-300	MKS-B-060300	300※	60	60	50	50	81	90	8.94
64010B-400	MKS-B-060400	400							14.28
64010B-500	MKS-B-060500	500							15.08
64010B-600	MKS-B-060600	600							16.87
64010B-700	MKS-B-060700	700							18.83
64012B-400	MKS-B-080400	400	80	80	60	60	99	95	21.66
64012B-500	MKS-B-080500	500							22.52
64012B-600	MKS-B-080600	600							25.16
64012B-700	MKS-B-080700	700							27.74
64012B-800	MKS-B-080800	800							30.39
64014B-400	MKS-B-100400	400	100	100	60	60	119	95	27.40
64014B-500	MKS-B-100500	500							28.62
64014B-600	MKS-B-100600	600							32.05
64014B-700	MKS-B-100700	700							35.43
64014B-800	MKS-B-100800	800							38.87

MKS-B

夾持示意圖 Clamping Range Demo

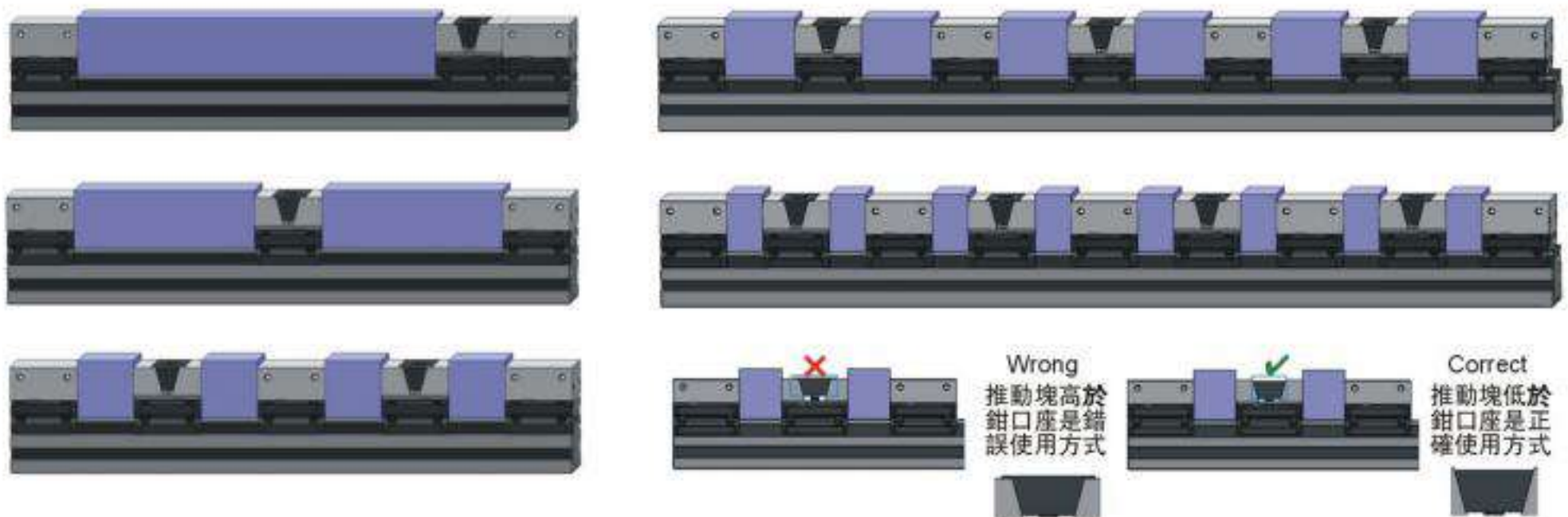

Wrong
推動塊高於
鉗口座是錯
誤使用方式

Correct
推動塊低於
鉗口座是正
確使用方式

Unit:mm

型號 Model	一個工件 1 workpiece	二個工件 2 workpiece	三個工件 3 workpiece	四個工件 4 workpiece
MKS-B-048300	150	75	--	--
MKS-B-048400	250	125	--	37
MKS-B-048500	350	175	--	62
MKS-B-048600	450	225	--	67
MKS-B-048700	550	275	--	92
MKS-B-060300	150	75	--	--
MKS-B-060400	250	125	--	37
MKS-B-060500	350	175	--	62
MKS-B-060600	450	225	--	67
MKS-B-060700	550	275	--	92
MKS-B-080400	220	110	--	17
MKS-B-080500	320	160	--	42
MKS-B-080600	420	210	--	67
MKS-B-080700	520	260	--	92
MKS-B-080800	620	310	--	117
MKS-B-100400	220	110	--	17
MKS-B-100500	320	160	--	42
MKS-B-100600	420	210	--	67
MKS-B-100700	520	260	--	92
MKS-B-100800	620	310	--	117
型號 Model	五個工件 5 workpiece	六個工件 6 workpiece	七個工件 7 workpiece	八個工件 8 workpiece
MKS-B-048300	--	--	--	--
MKS-B-048400	--	--	--	--
MKS-B-048500	--	24	--	12
MKS-B-048600	--	40	--	24
MKS-B-048700	--	58	--	36
MKS-B-060300	--	--	--	--
MKS-B-060400	--	--	--	--
MKS-B-060500	--	24	--	12
MKS-B-060600	--	40	--	24
MKS-B-060700	--	58	--	36
MKS-B-080400	--	--	--	--
MKS-B-080500	--	12	--	--
MKS-B-080600	--	30	--	6
MKS-B-080700	--	46	--	20
MKS-B-080800	--	62	--	32
MKS-B-100400	--	--	--	--
MKS-B-100500	--	12	--	--
MKS-B-100600	--	30	--	6
MKS-B-100700	--	46	--	20
MKS-B-100800	--	62	--	32

MCS-C

模組化並列式虎鉗

Modular Clamping System

MCS-C單口下拉夾持系列Single lockdown series

MCS-C=GL50+CZ+CC+CE

Tool steel **M** 工具鋼

H HRC48°~50°

F 2000kgf

特點Features:

- ▲ 夾持鉗口組, 拆裝簡單, 位移方便, 容易清潔。
- ▲ 因夾持鉗口設計下拉推動, 夾持工件滿載時, 上浮量可維持5μ以內。
- ▲ 多台並列運用於機床上夾持工作, 可做到量加工產出。
- ▲ Operation increasing efficiency.
- ▲ Lockdown mechanism, when workpiece is fully clamped keeping lifting within in 0.005mm.
- ▲ Mass production by applying multiple parallel-use.

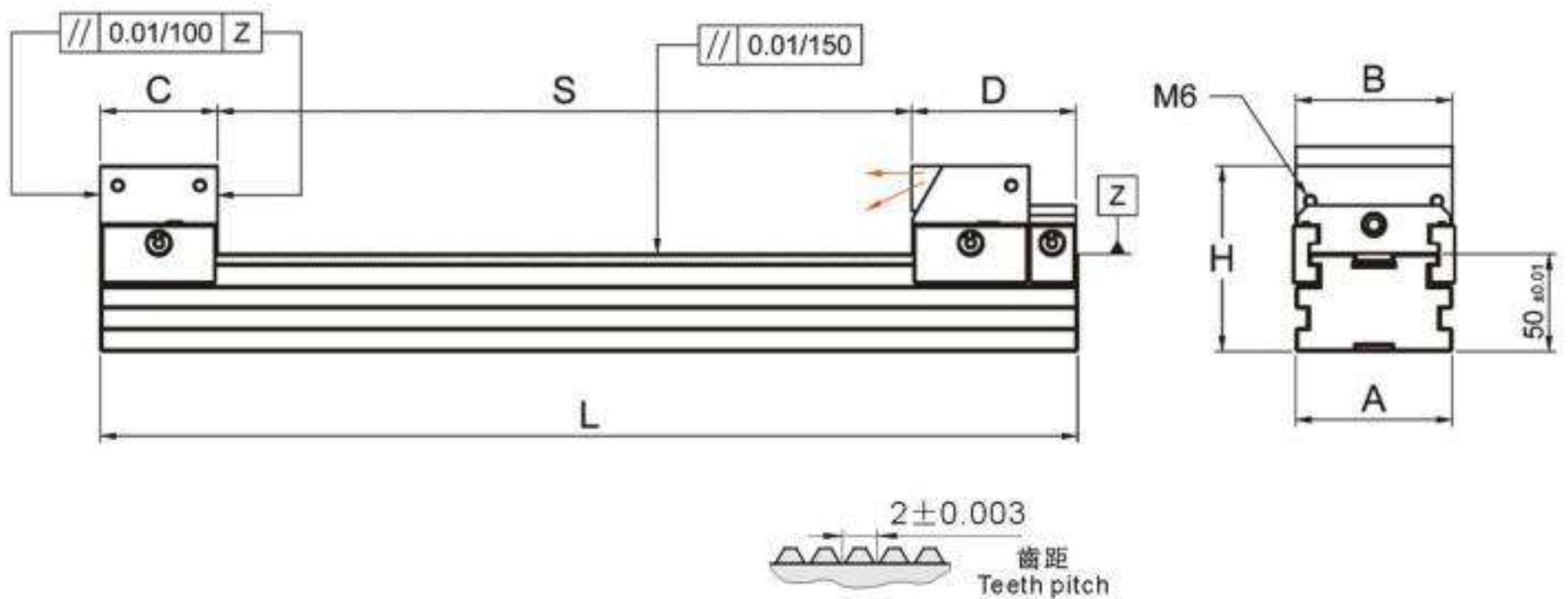
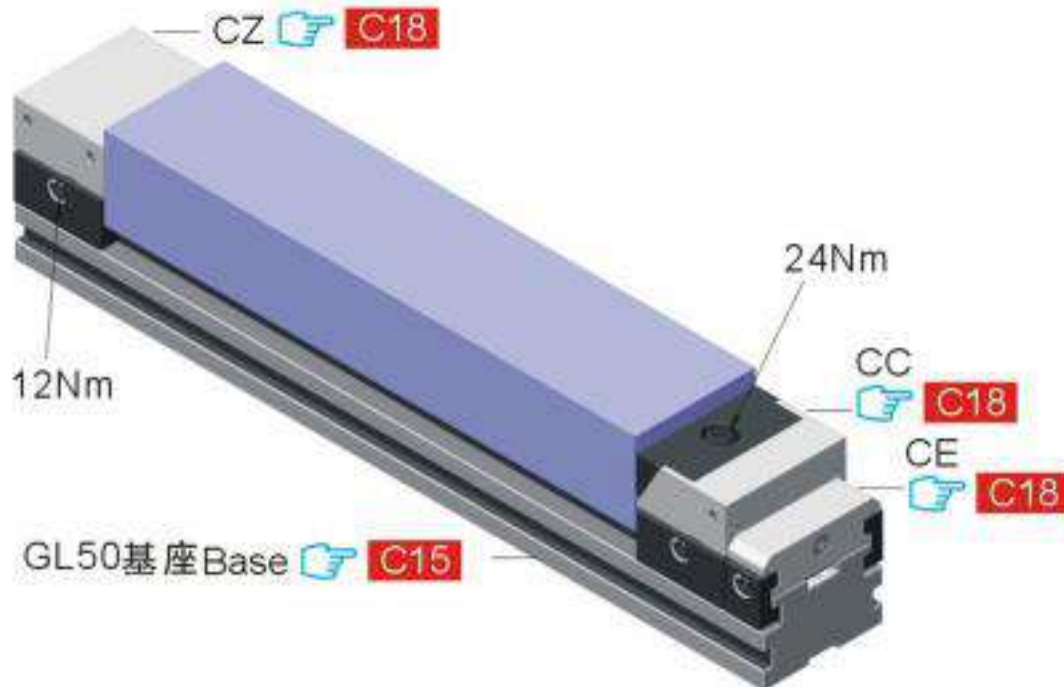

Unit:mm

訂購編號 Order No.	型號 Model	L	A	B	C	D	H	S	N.W.(kg)
64016C-400	MCS-C-080400	400	80	80	60	84	95	0~255	14.10
64016C-500	MCS-C-080500	500						0~355	16.83
64016C-600	MCS-C-080600	600						0~455	19.43
64016C-700	MCS-C-080700	700						0~555	21.96
64016C-800	MCS-C-080800	800						0~655	24.56
64018C-400	MCS-C-100400	400	100	100	60	84	95	0~255	18.23
64018C-500	MCS-C-100500	500						0~355	21.75
64018C-600	MCS-C-100600	600						0~455	23.11
64018C-700	MCS-C-100700	700						0~555	25.14
64018C-800	MCS-C-100800	800						0~655	26.48

MCS-D 模組化並列式虎鉗

Modular Clamping System

MCS-D雙口下拉夾持系列 Double lockdown series

MCS-D=GL50+CZ+CC+CE

Tool steel **M** 工具鋼

H HRC48°~50°

F 2000kgf

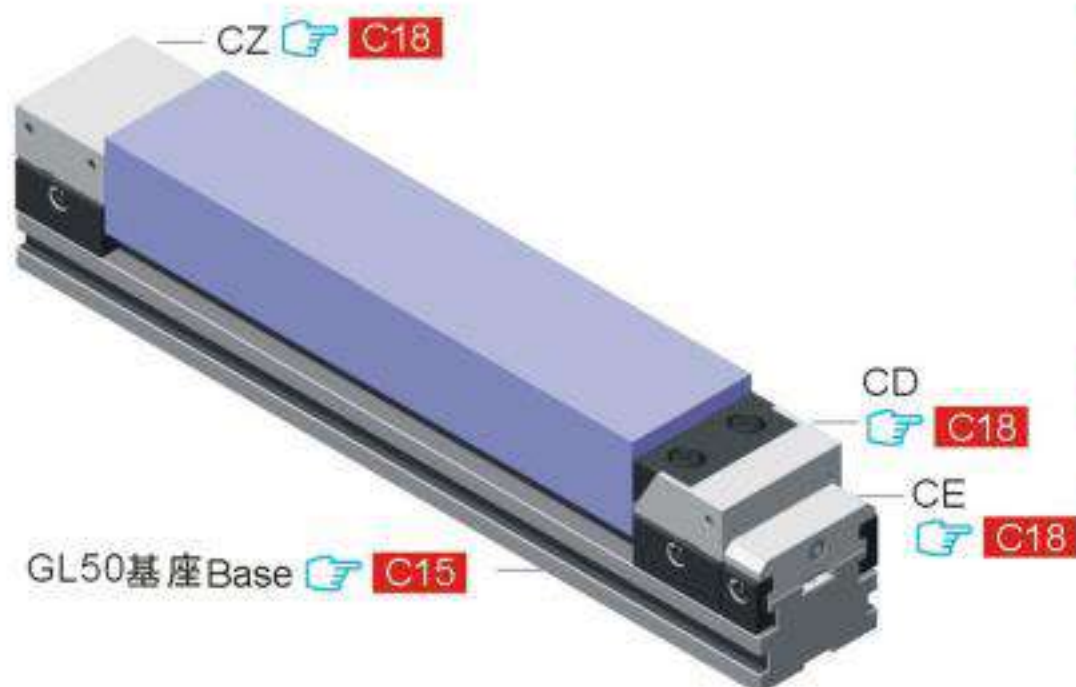

特點 Features:

- ▲ 夾持鉗口組, 拆裝簡單, 位移方便, 容易清潔。
- ▲ 因夾持鉗口設計下拉推動, 夾持工件滿載時, 上浮量可維持5 μ 以內。
- ▲ 多台並列運用於機床上夾持工作, 可做到量加工產出。
- ▲ Operation increasing efficiency.
- ▲ Lockdown mechanism, when workpiece is fully clamped keeping lifting within in 0.005mm.
- ▲ Mass production by applying multiple parallel-use.

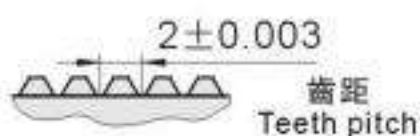
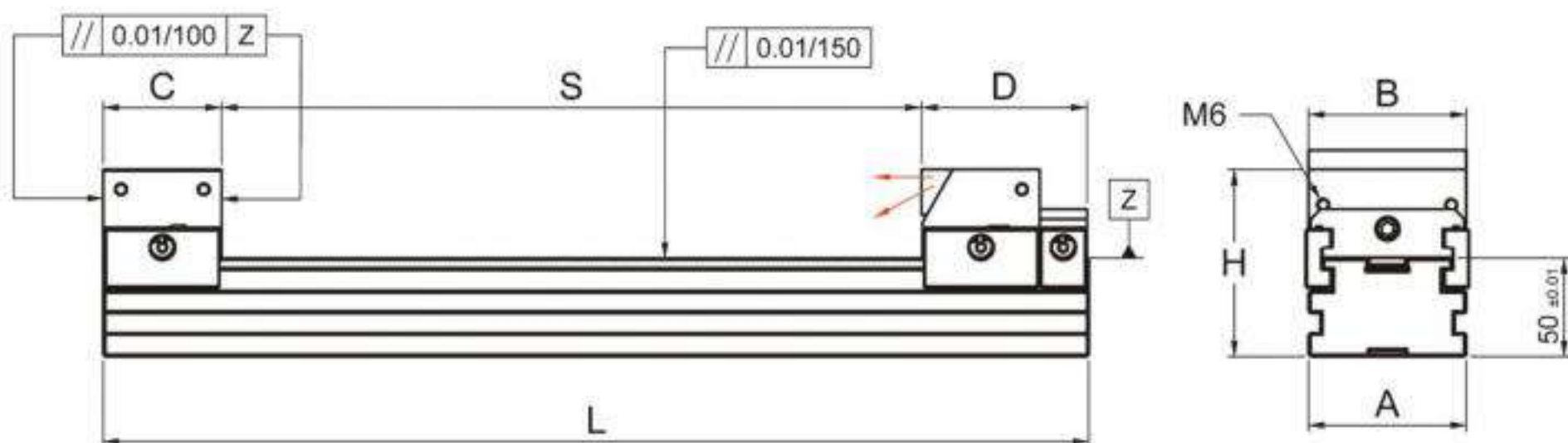

Unit:mm

訂購編號 Order No.	型號 Model	L	A	B	C	D	H	S	N.W.(kg)
64020D-400	MCS-D-080400	400	80	80	60	84	95	0~255	14.07
64020D-500	MCS-D-080500	500						0~355	16.80
64020D-600	MCS-D-080600	600						0~455	19.40
64020D-700	MCS-D-080700	700						0~555	21.93
64020D-800	MCS-D-080800	800						0~655	24.53
64022D-400	MCS-D-100400	400	100	100	60	84	95	0~255	18.20
64022D-500	MCS-D-100500	500						0~355	21.72
64022D-600	MCS-D-100600	600						0~455	23.08
64022D-700	MCS-D-100700	700						0~555	25.11
64022D-800	MCS-D-100800	800						0~655	26.45

MKS

並列式虎鉗轉接系列

MKS Adaptor series

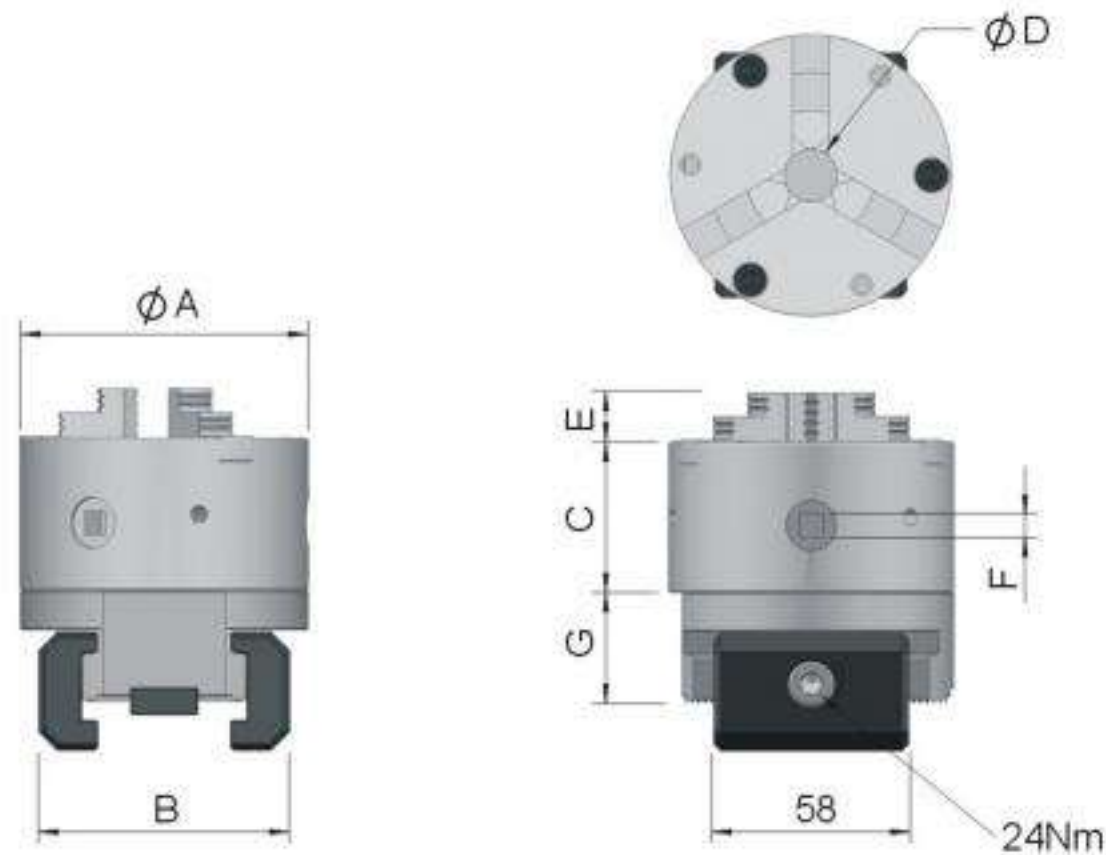

三爪夾頭連接座組

Jaw Chuck & Adaptor for MKS

M 軸承鋼 SUJ2 H HRC45°~50°

Unit:mm

訂購編號 Order No.	型號 Model	A	B	C	D	E	F	G	N.W.(kg)
64024-060	CJ060	85	74	45	16	15	7	32.1	3.49
64024-080	CJ080	112	92	58	24	17	8	32.1	6.58
64024-100	CJ100	132	112	60	32	20	8	32.1	9.56

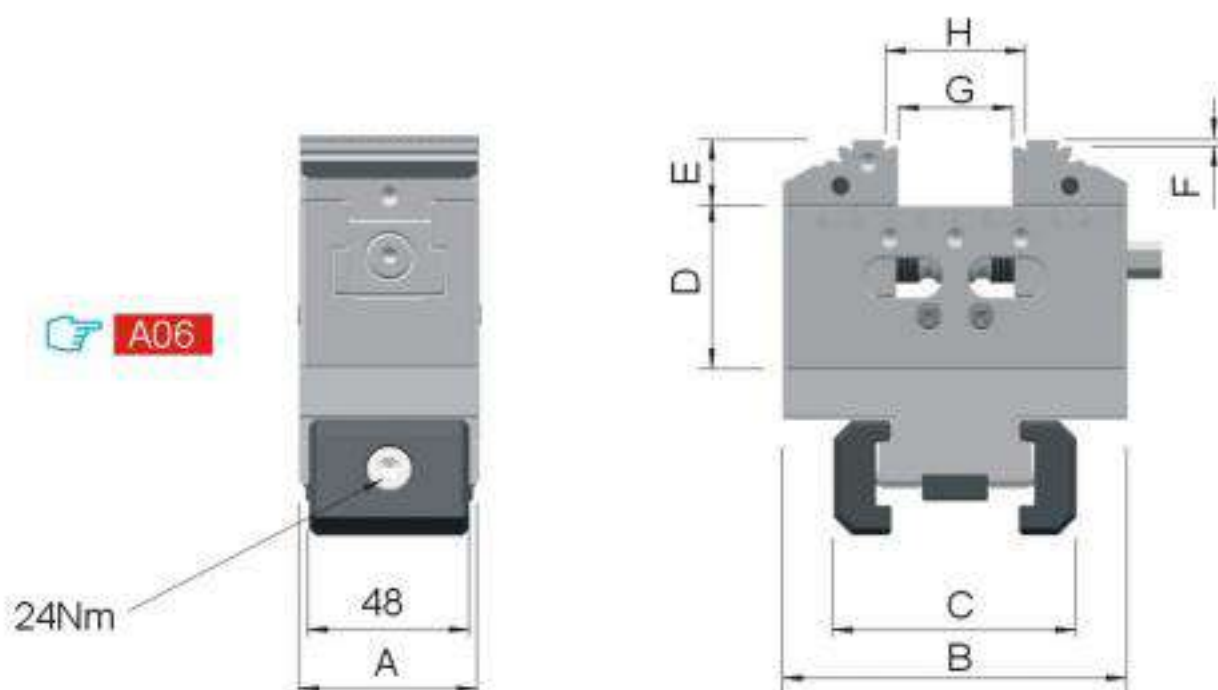

求心虎鉗連接座組

PQV204V Vise & Adaptor for MKS

M 預硬鋼 P75

Unit:mm

訂購編號 Order No.	型號 Model	A	B	C	D	E	F	G	H	N.W.(kg)
64026-060	CP060	54	105	74	50	20	2	0~35	8~43	3.49

並列式虎鉗轉接座使用數量示意圖 MKS Adaptor Application

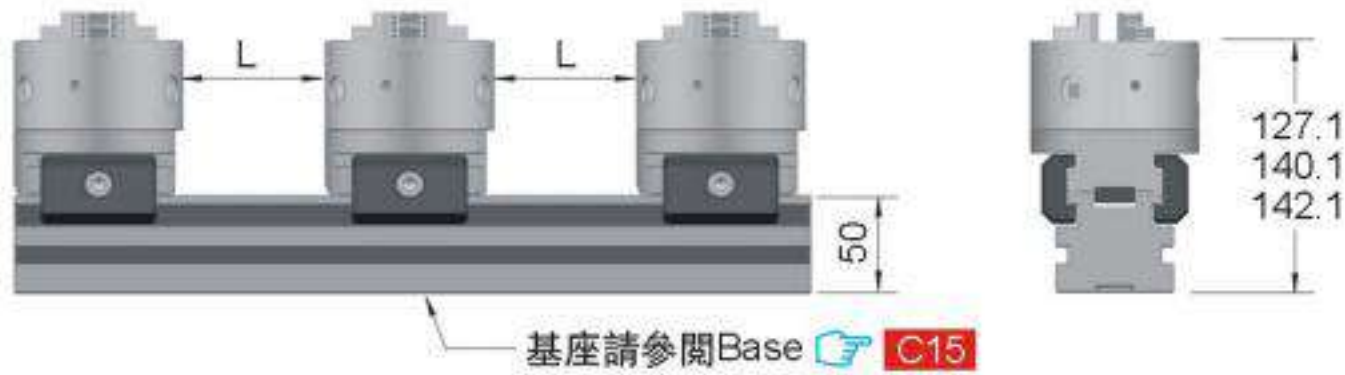

三爪夾頭並列使用數量與間距

Distance between qty of chuck applied.

Unit:mm

型號 Model	二個夾頭 (L) 2 chucks (L)	三個夾頭 (L) 3 chucks (L)	四個夾頭 (L) 4 chucks (L)	五個夾頭 (L) 5 chucks (L)	六個夾頭 (L) 6 chucks (L)
MKS-CJ-060300	129	21	--	--	--
MKS-CJ-060400	229	71	19	--	--
MKS-CJ-060500	329	121	53	--	--
MKS-CJ-060600	429	171	85	41	17
MKS-CJ-060700	529	221	119	65	37
MKS-CJ-080400	176	32	--	--	--
MKS-CJ-080500	276	82	16	--	--
MKS-CJ-080600	376	132	50	10	--
MKS-CJ-080700	476	182	84	34	--
MKS-CJ-080800	576	232	116	60	24
MKS-CJ-100400	136	2	--	--	--
MKS-CJ-100500	236	52	--	--	--
MKS-CJ-100600	336	102	24	--	--
MKS-CJ-100700	436	152	56	10	--
MKS-CJ-100800	536	202	90	34	--



求心虎鉗並列使用數量與間距

Distance between qty of self-centering vise (PQV204V) applied. ([A06](#))

Unit:mm

型號 Model	二個虎鉗 (L) 2 vises (L)	三個虎鉗 (L) 3 vises (L)	四個虎鉗 (L) 4 vises (L)	五個虎鉗 (L) 5 vises (L)	六個虎鉗 (L) 6 vises (L)	七個虎鉗 (L) 7 vises (L)	八個虎鉗 (L) 8 vises (L)	九個虎鉗 (L) 9 vises (L)
MKS-CP-060300	192	68	28	6	--	--	--	--
MKS-CP-060400	292	118	60	32	14	--	--	--
MKS-CP-060500	392	168	94	56	34	20	8	--
MKS-CP-060600	492	218	128	82	54	36	24	14
MKS-CP-060700	592	268	160	106	74	52	38	26

MKS

GL50基座系列 (寬60mm)

GL50 Base series (60mm)

300mm

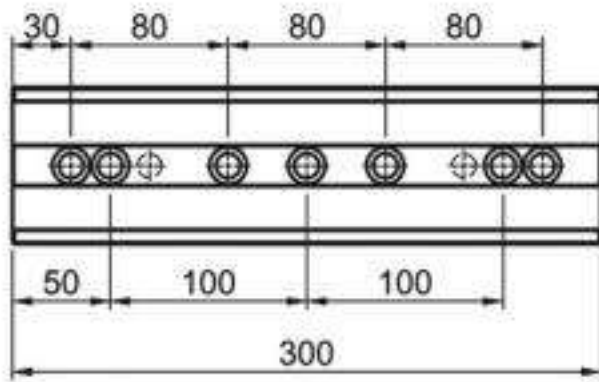

400mm

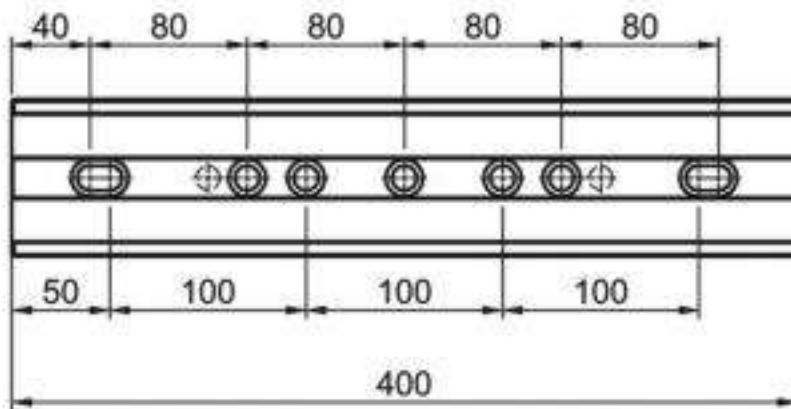

500mm

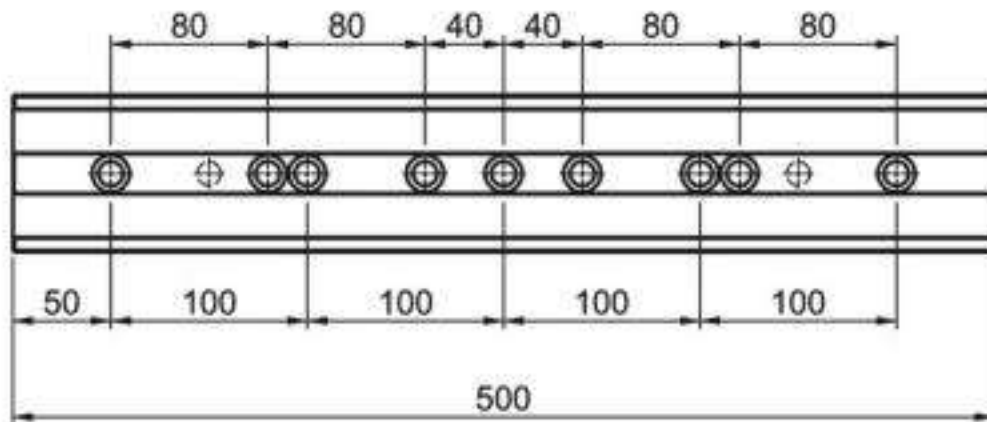

600mm

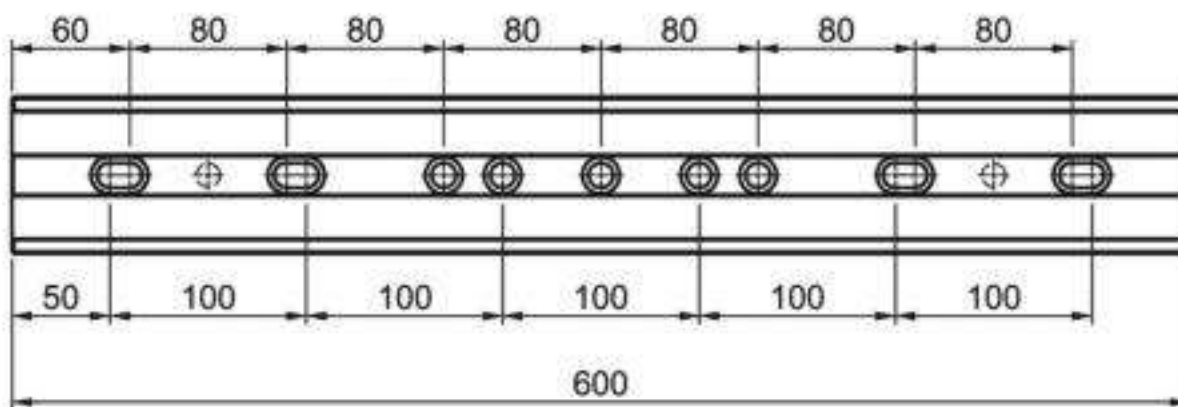

700mm

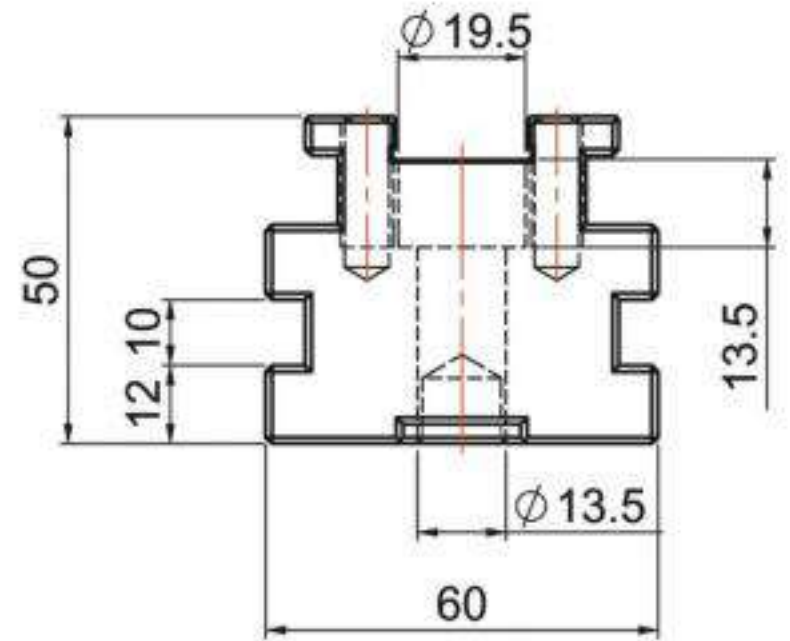
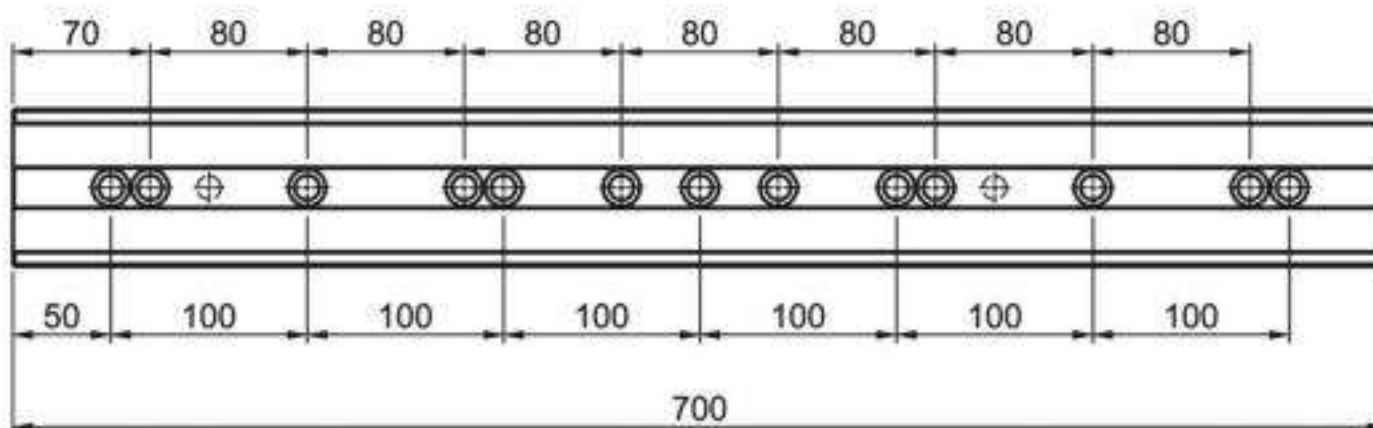

GL50-060  **C15**

GL50基座系列 (寬80/100mm)
GL50 Base series (80/100mm)

400mm

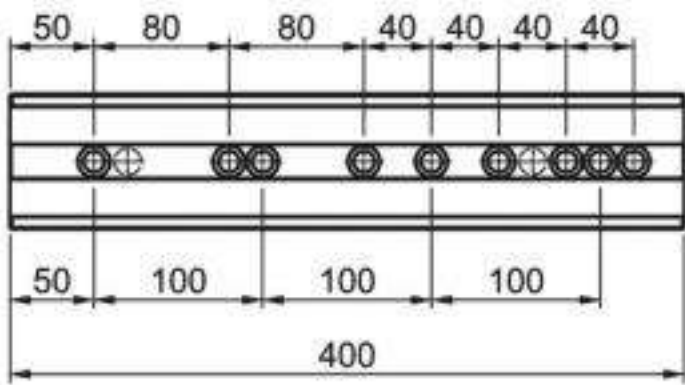

500mm

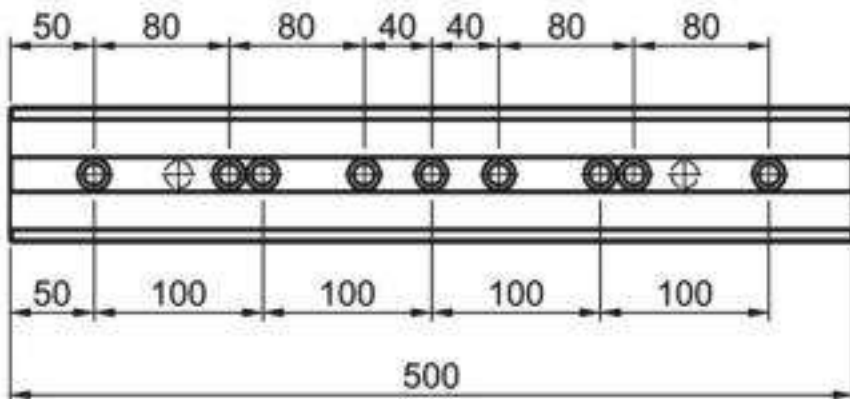

600mm

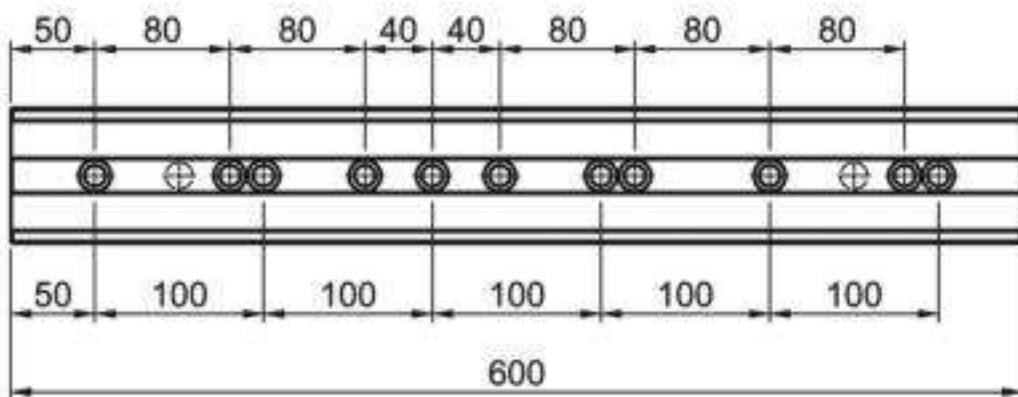

700mm

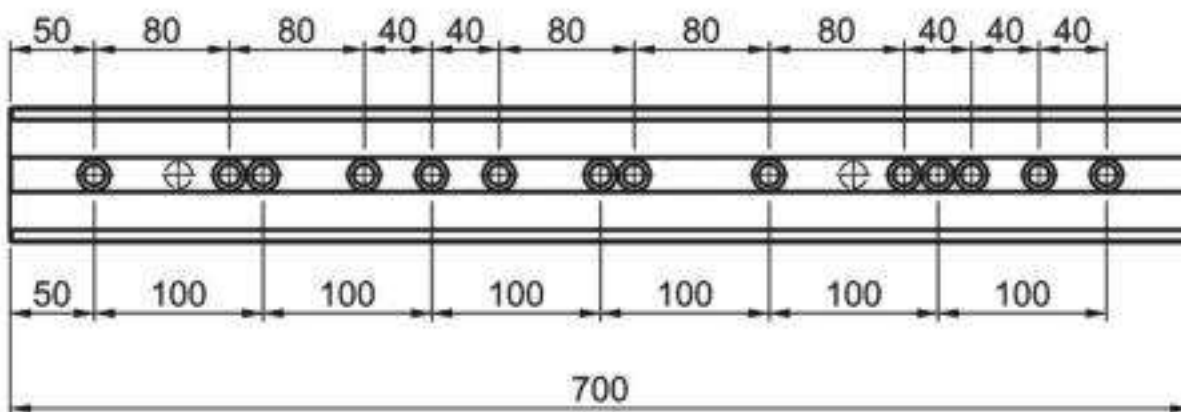

800mm

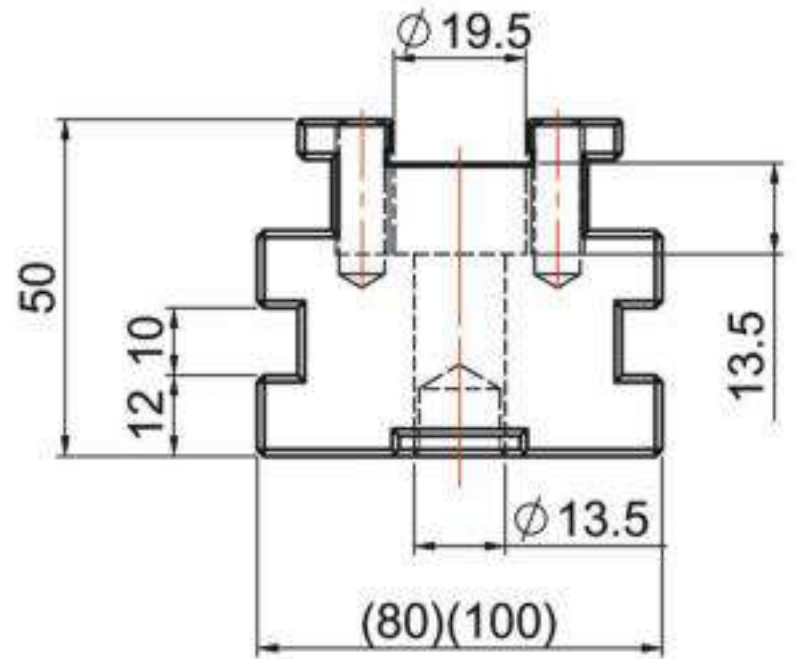
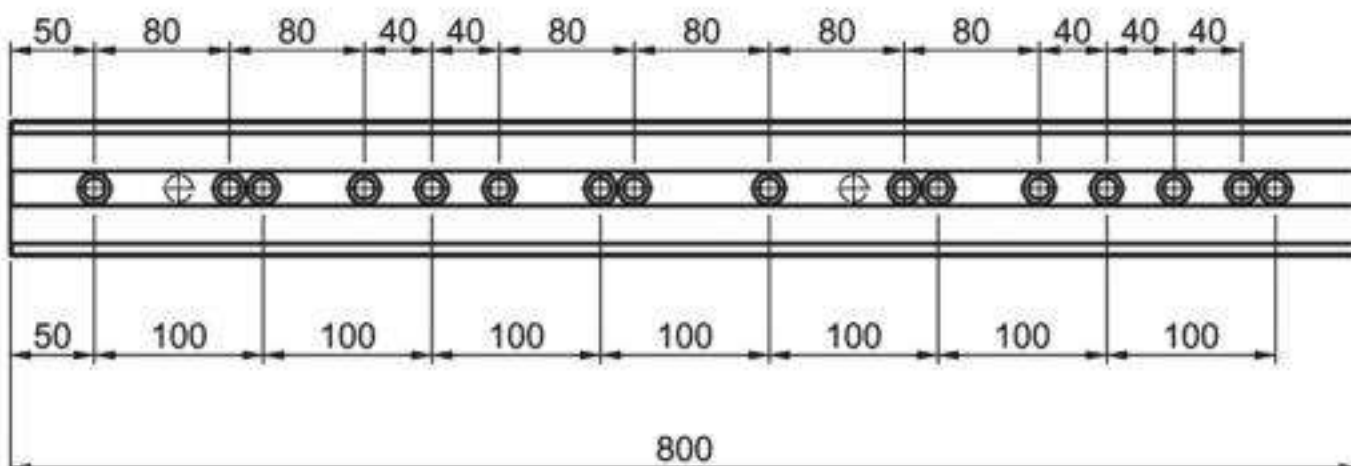

GL50-080 **C15**

GL50-100 **C15**

MKS

GL50基座系列

GL50 Base series

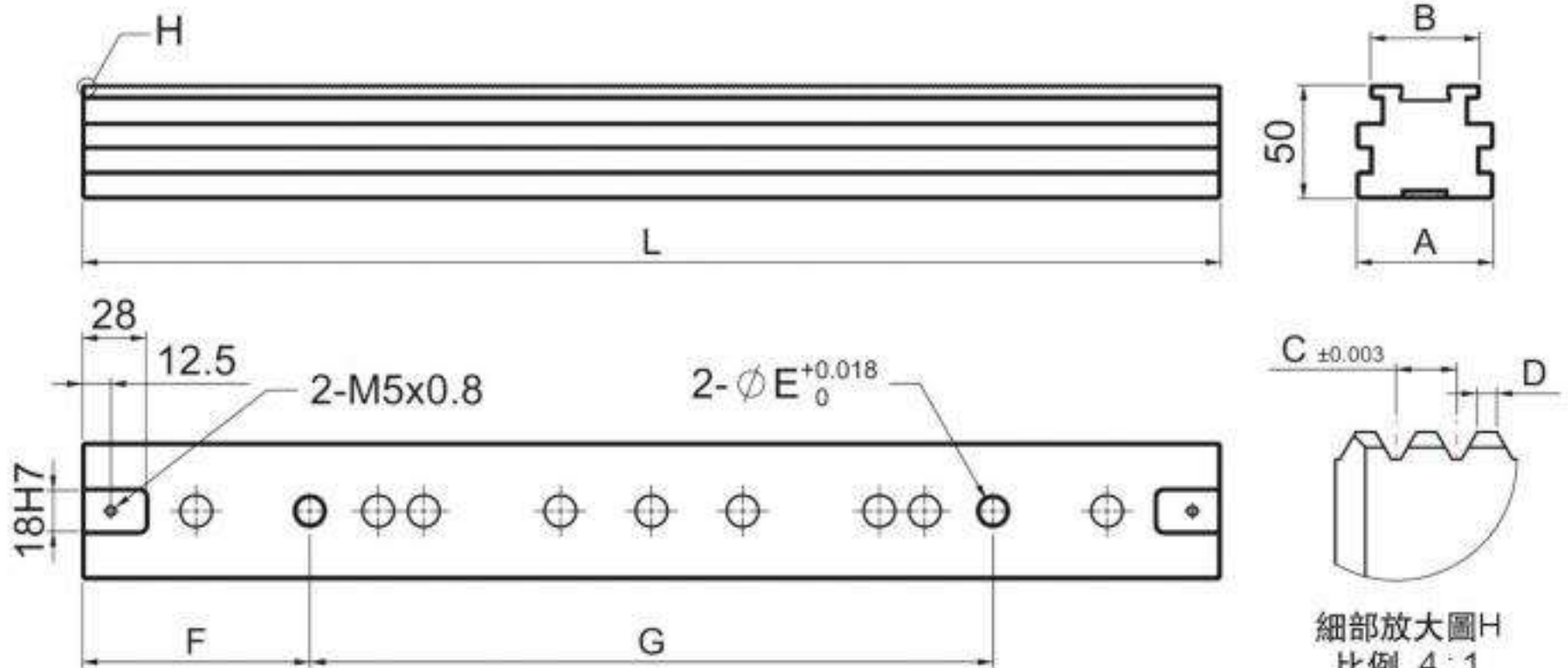

詳細尺寸規格請參閱 [C13~14](#)
Specs refer to

細部放大圖H
比例 4:1
Detail H
Scale 4:1

M SCM440 **H** HRC48°~50°

Unit:mm

訂購編號 Order No.	型號 Model	L	A	B	C	D	E	F	G	N.W.(kg)
64500G-300	GL50-060300	300						70	160	5.34
64500G-400	GL50-060400	400							200	7.19
64500G-500	GL50-060500	500	60	48	2	0.654	12	100	300	9.13
64500G-600	GL50-060600	600							400	10.87
64500G-700	GL50-060700	700							400	12.77
64502G-400	GL50-080400	400						70	240	10.21
64502G-500	GL50-080500	500							300	12.94
64502G-600	GL50-080600	600	80	66	2	0.654	16	100	400	15.53
64502G-700	GL50-080700	700							400	18.05
64502G-800	GL50-080800	800							400	20.65
64504G-400	GL50-100400	400						70	240	13.38
64504G-500	GL50-100500	500							300	16.91
64504G-600	GL50-100600	600	100	86	2	0.654	16	100	400	20.29
64504G-700	GL50-100700	700							400	23.66
64504G-800	GL50-100800	800							400	27.00

備注：整組含基座刻度板螺絲 Remark: graduation ruler and screws are included in set.

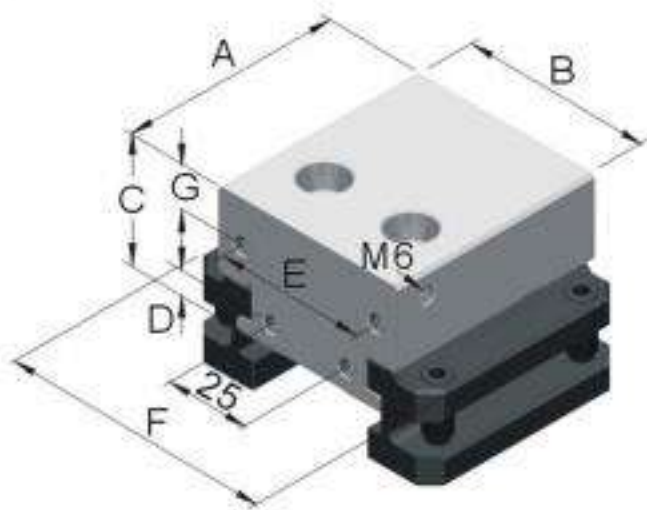

AZ固定鉗口組
AZ Fixed block

M 工具鋼 (Tool steel)
H HRC48°~50°

Unit:mm

訂購編號 Order No.	型號 Model	A	B	C	D	E	F	G	N.W.(kg)
64028A-048	AZ048	66	48	40	8	35	81	14	1.35
64028A-060	AZ060	66	60	40	8	45	81	14	1.51
64028A-080	AZ080	66	80	45	10	65	99	18	2.09
64028A-100	AZ100	66	100	45	10	85	119	18	2.56

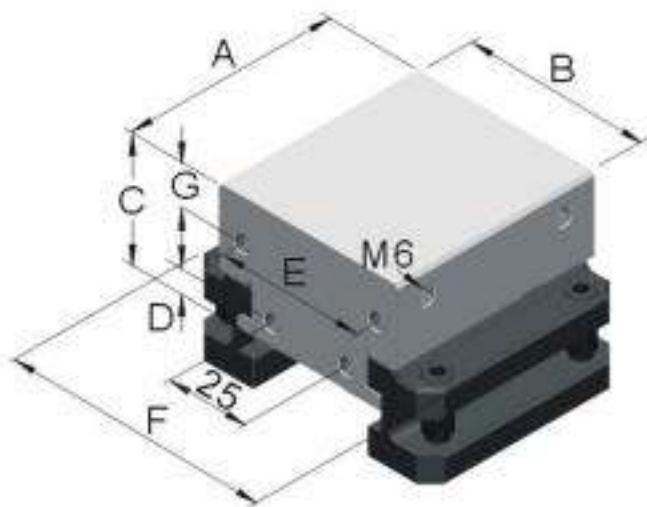

BZ固定鉗口組
BZ Fixed block

M 工具鋼 (Tool steel)
H HRC48°~50°

Unit:mm

訂購編號 Order No.	型號 Model	A	B	C	D	E	F	G	N.W.(kg)
64030B-048	BZ048	50	48	40	8	35	81	14	1.05
64030B-060	BZ060	50	60	40	8	45	81	14	1.17
64030B-080	BZ080	60	80	45	10	65	99	18	1.90
64030B-100	BZ100	60	100	45	10	85	119	18	2.33

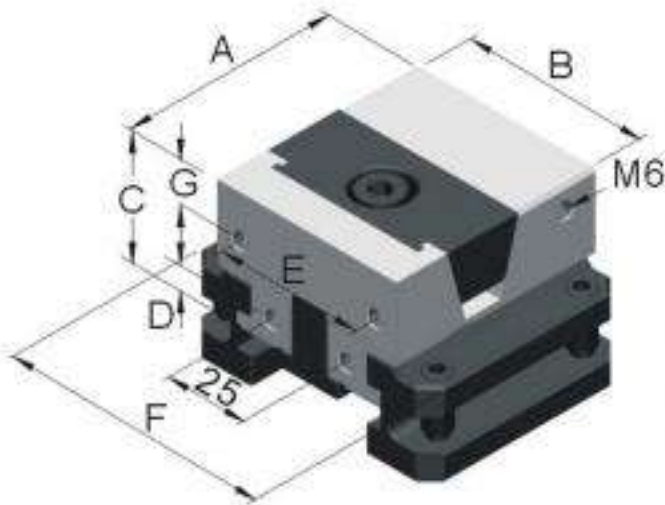

KA單向平行夾持鉗口組
KA One-side lockdown

M 工具鋼 (Tool steel)
H HRC43°~45°

Unit:mm

訂購編號 Order No.	型號 Model	A	B	C	D	E	F	G	N.W.(kg)
64032A-048	KA048	66	48	40	8	35	81	14	1.33
64032A-060	KA060	66	60	40	8	45	81	14	1.49
64032A-080	KA080	72	80	45	10	65	99	18	2.24
64032A-100	KA100	72	100	45	10	85	119	18	2.74

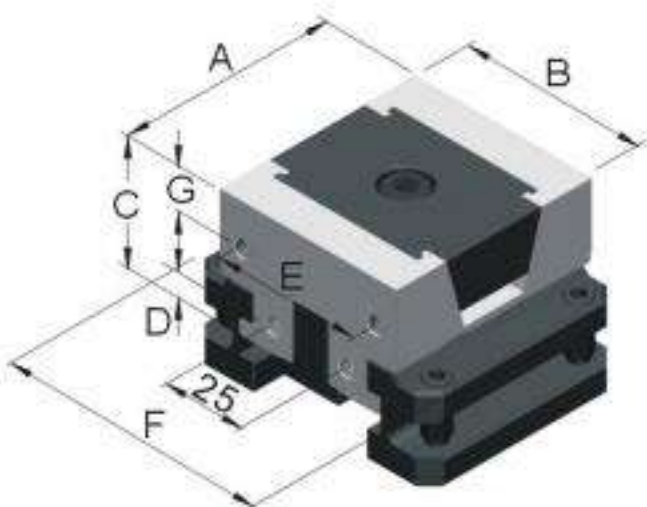

KB雙向平行夾持鉗口組
KB Dual-side lockdown

M 工具鋼 (Tool steel)
H HRC43°~45°

Unit:mm

訂購編號 Order No.	型號 Model	A	B	C	D	E	F	G	N.W.(kg)
64034B-048	KB048	50	48	40	8	35	81	14	1.00
64034B-060	KB060	50	60	40	8	45	81	14	1.11
64034B-080	KB080	60	80	45	10	65	99	18	1.82
64034B-100	KB100	60	100	45	10	85	119	18	2.23

標準固定夾持件 Standard Clamps

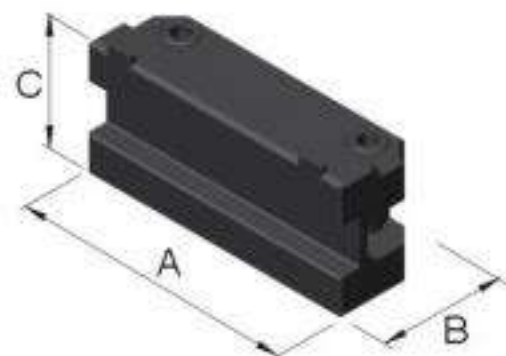

K型夾持塊
K Clamp

M SNCM439
H HRC30°

Unit:mm

訂購編號 Order No.	型號 Model	A	B	C	N.W.(kg)
64044A-001	KA	65	21.5	31.7	0.23
64044A-002	KB	49	21.5	31.7	0.17

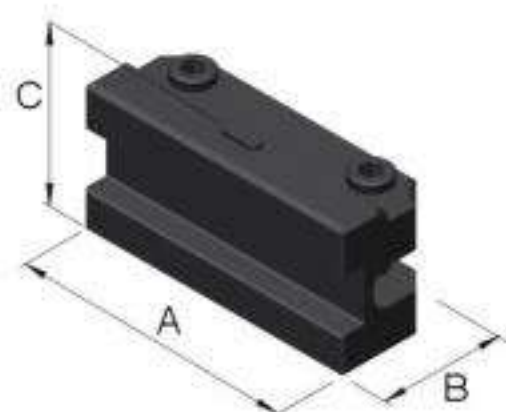

K型夾持塊
K Clamp

M SNCM439
H HRC30°

Unit:mm

訂購編號 Order No.	型號 Model	A	B	C	N.W.(kg)
64045K-001	KN	58	21.5	30.3	0.21

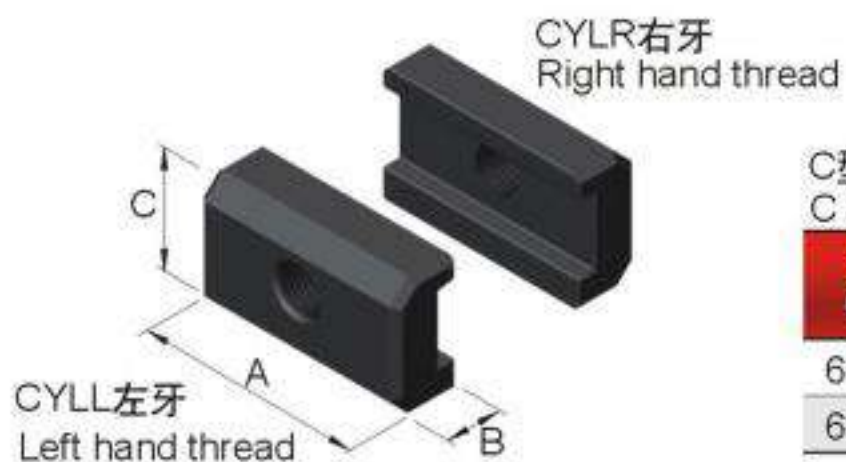

C型夾持塊
C Clamp

M 工具鋼(Tool steel)
H HRC28°~34°
S QPQ HV950°

Unit:mm

訂購編號 Order No.	型號 Model	A	B	C	N.W.(kg)
64046C-001	CYLR	58	17.5	35	0.21
64046C-002	CYLL	58	17.5	35	0.21

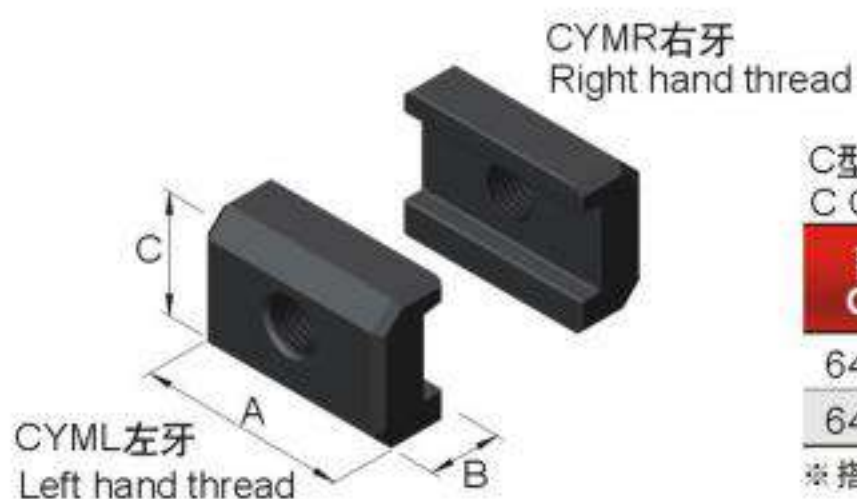

C型夾持塊
C Clamp

M 工具鋼(Tool steel)
H HRC28°~34°
S QPQ HV950°

Unit:mm

訂購編號 Order No.	型號 Model	A	B	C	N.W.(kg)
64048C-001	CYMR	48	17.5	35	0.17
64048C-002	CYML	48	17.5	35	0.17

※ 搭配精密快速求心虎鉗使用 ※ Compatible for PQV204V use

標準鉗口組件與固定夾持件 Standard Clamps and Blocks

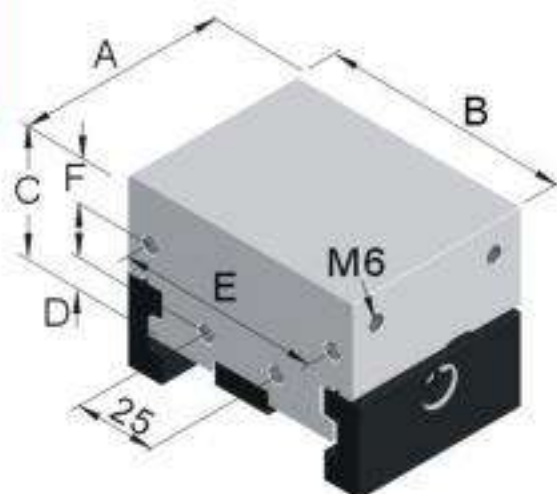

CZ固定鉗口組
CZ Fixed block

M 工具鋼(Tool steel)
H HRC48°~50°

Unit:mm

訂購編號 Order No.	型號 Model	A	B	C	D	E	F	N.W.(kg)
64066-080	CZ080	60	80	45	10	65	18	1.81
64066-100	CZ100	60	100	45	10	85	18	2.24

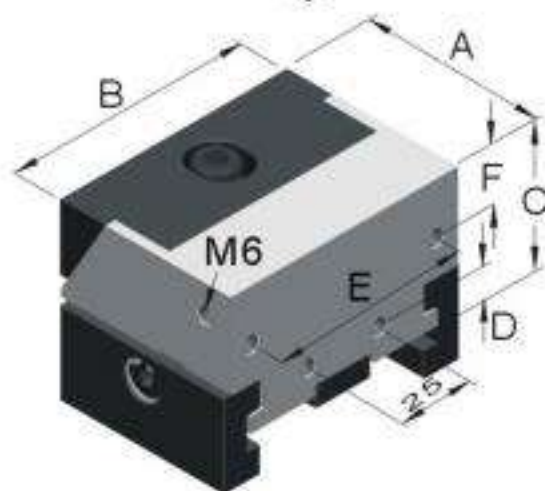

CC單口下拉夾持鉗口組
CC One-side lockdown

M 工具鋼(Tool steel)
H HRC48°~50°

Unit:mm

訂購編號 Order No.	型號 Model	A	B	C	D	E	F	N.W.(kg)
64072-080	CC080	60	80	45	10	65	18	1.69
64072-100	CC100	60	100	45	10	85	18	2.12

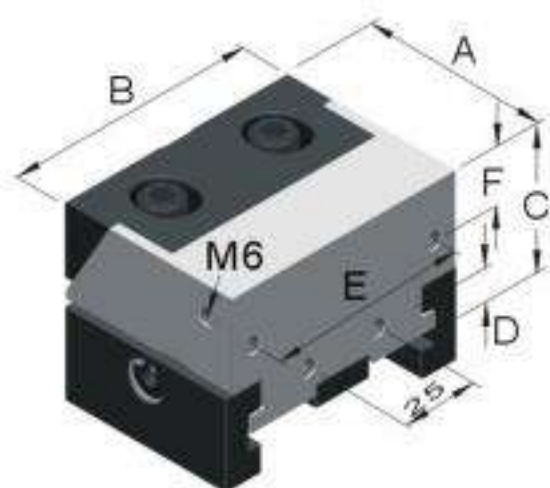

CD雙口下拉夾持鉗口組
CD Dual-side lockdown

M 工具鋼(Tool steel)
H HRC48°~50°

Unit:mm

訂購編號 Order No.	型號 Model	A	B	C	D	E	F	N.W.(kg)
64074-080	CD080	60	80	45	10	65	18	1.67
64074-100	CD100	60	100	45	10	85	18	2.09

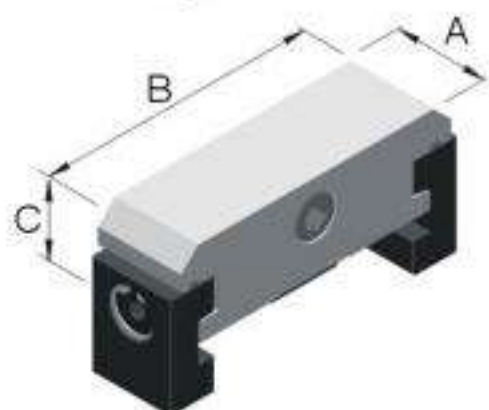

CE固定塊組
CE Fixed block

M 工具鋼(Tool steel)
H HRC28°~34°
S QPQ HV950°

Unit:mm

訂購編號 Order No.	型號 Model	A	B	C	N.W.(kg)
64078-080	CE080	24	78	25	1.85
64078-100	CE100	24	98	25	2.27

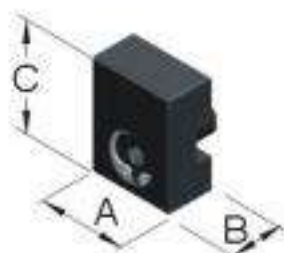

C型夾持塊
C Clamp

M 工具鋼(Tool steel)
H HRC28°~34°
S QPQ HV950°

Unit:mm

訂購編號 Order No.	型號 Model	A	B	C	N.W.(kg)
64090-001	CS	23	13	29.5	0.05

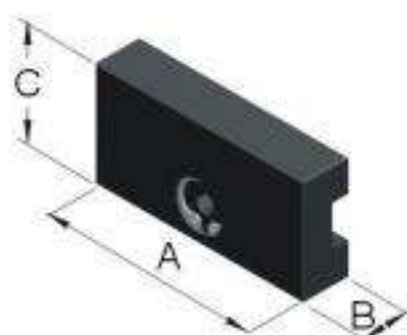

C型夾持塊
C Clamp

M 工具鋼(Tool steel)
H HRC28°~34°
S QPQ HV950°

Unit:mm

訂購編號 Order No.	型號 Model	A	B	C	N.W.(kg)
64090-002	CM	48	13	29.5	0.11
64090-003	CL	58	13	29.5	0.21

並列式虎鉗特別附件 (選購品)

Accessories (Optional)



基準靠板 (M6牙)
Datum Plate (M6 thread)

M 工具鋼 (Tool steel)
H HRC45°

Unit:mm

訂購編號 Order No.	型號 Model	A	B	C	N.W.(kg)
64100-38	DPM048060	38	9.5	16	0.05

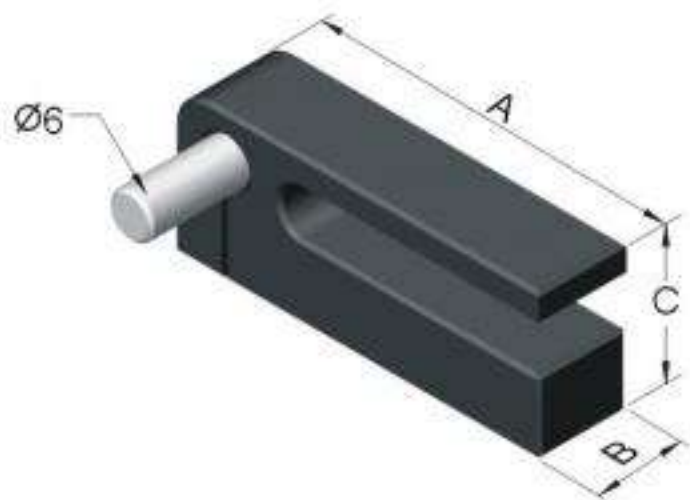

基準靠板 (孔)
Datum Plate (Pin Hole)

M 工具鋼 (Tool steel)
H HRC45°

Unit:mm

訂購編號 Order No.	型號 Model	A	B	C	N.W.(kg)
64110-50	DPD048060	50	12	20	0.05
64110-60	DPD080100	60	12	20	0.06

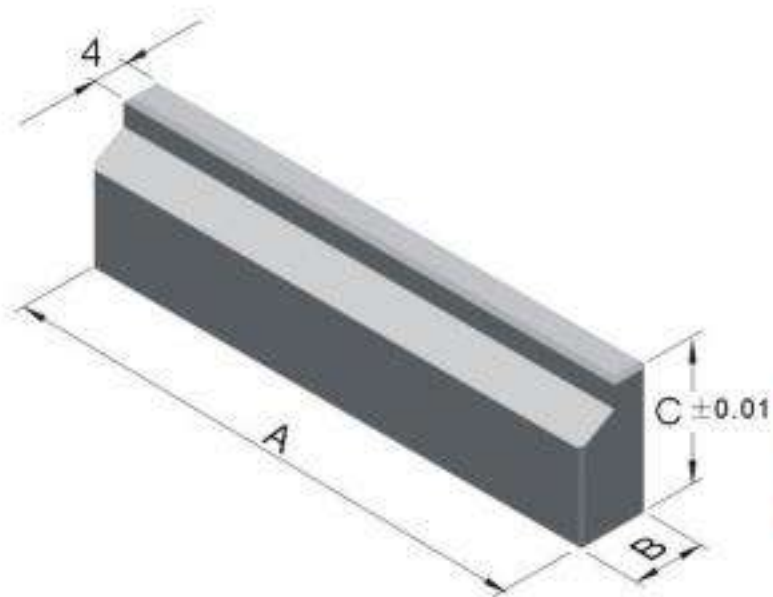

平行墊板
Parallels

M 工具鋼 (Tool steel)
H HRC45°

Unit:mm

訂購編號 Order No.	型號 Model	A	B	C	N.W.(kg)
64120-04835	MP04835	48	8	35	0.05
64120-04838	MP04838			38	0.07
64120-06035	MP06035	60	8	35	0.06
64120-06038	MP06038			38	0.09
64120-08040	MP08040	80	8	40	0.09
64120-08043	MP08043			43	0.12
64120-10040	MP10040	100	8	40	0.12
64120-10043	MP10043			43	0.16

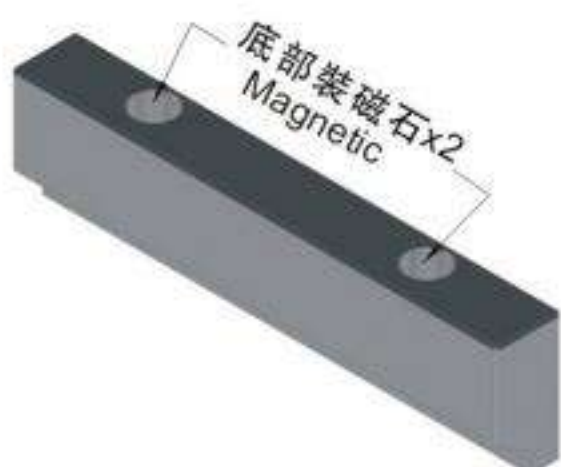

並列式虎鉗特別附件 (選購品) Accessories (Optional)

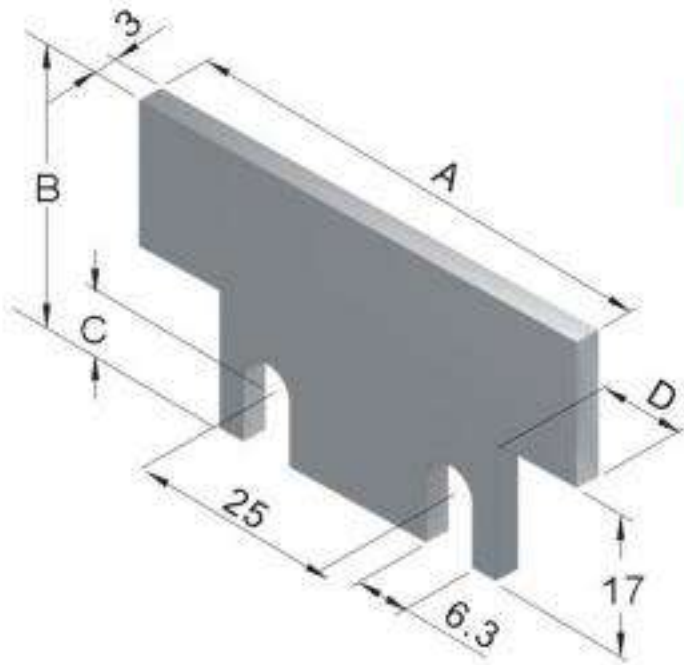

墊板
Spacer

M 工具鋼 (Tool steel)
H HRC45°

Unit:mm

訂購編號 Order No.	型號 Model	A	B	C	D	N.W.(kg)
64130-04835	SP04835	47.8	35	8	5	0.04
64130-04838	SP04838		38			0.05
64130-06035	SP06035	59.8	35	8	11	0.06
64130-06038	SP06038		38			0.07
64130-08040	SP08040	79.8	40	10	12	0.10
64130-08043	SP08043		43			0.10
64130-10040	SP10040	99.8	40	10	12	0.13
64130-10043	SP10043		43			0.14

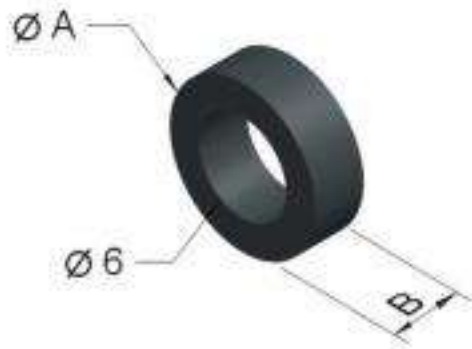

墊圈
Spacer

M 工具鋼 (Tool steel)
H HRC45°

Unit:mm

訂購編號 Order No.	型號 Model	A	B	C
64140-A	SPACER-A	10	3.5	用於A型, 使用2個 MKS-A, 2 pcs
64140-B	SPACER-B		2	用於B型, 使用4個 MKS-A, 4 pcs

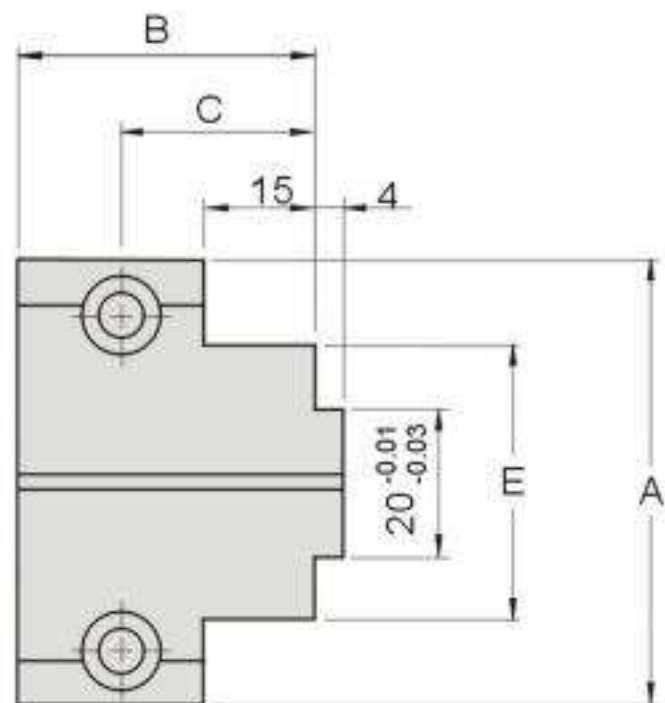
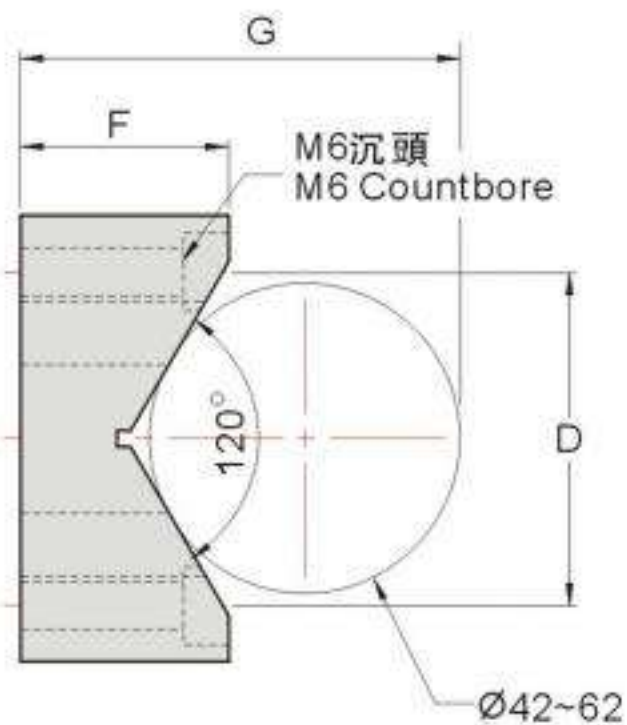

V型鉗口(A型B型用)
V-Clamp(for MKS-A & B)

M 工具鋼 (Tool steel)
H HRC48°~50°

Unit:mm

訂購編號 Order No.	型號 Model	A	B	C	D	E	F	G	CLAMP(MAX)	N.W.(kg)
64160-048	JAW-048	48	40	26	35	37	23	57.279	Ø70	0.28
64160-060	JAW-060	60	40	26	45	37	28	59.392	Ø90	0.42
64160-080	JAW-080	80	45	27	65	55	38	86.032	Ø125	0.86
64160-100	JAW-100	100	45	27	85	75	48	91.124	Ø160	1.36

■ 技術領先 品質絕佳 零配件的首選

高自製率 · 30年製造經驗 · 設備領先齊全

自1988年成立以來，精展一直致力於提高生產效率和產品質量，以滿足客戶的需求。我們的產品覆蓋面和品種不斷創新和改進，不僅保持了同樣的質量性能，而且在市場上具有競爭優勢。

精展主要生產磨床、銑床等工具機配件和模具零配件。因客戶的信賴及支持，更因應客戶的需求，我們推出了【模組化並列式虎鉗】系列產品，提供多種夾緊解決方案。領先的技術水平，先進的加工設備，優異、穩定的表現深獲客戶贊譽。

精展歷經磨練，立於行業之巔，以貼心服務客戶的設計理念。協助客戶提高生產效率，降低製造成本。精展精密，最值得信賴的零配件製造商。

[品質、信用、可靠、專業]是精展堅持貫徹的經營理念，我們懷抱貢獻產業的使命，不斷成長茁壯，用前瞻視野洞悉客戶未來需求，期許以多年的專業經驗與突破性的創新動力，提供更高效率、節能的零配件產品，協助客戶開創未來競爭力，精展總是為您想的更多。

總經理 /



加工設備

- CNC 臥式加工中心機 (300mm 四方工作盤 x 10座)
- CNC 臥式加工中心機 (400mm 四方工作盤 x 10座)
- CNC 臥式加工中心機 (400mm 四方工作盤 x 2座)
- CNC 臥式加工中心機 (400mm 四方工作盤 x 24座)
- CNC 五面加工中心機 (400mm 四方工作盤 x 2座)
- CNC 五面加工中心機 (300mm 四方工作盤 x 10座)
- CNC 五軸同動加工中心機 (150 x 150mm 盤 x 180座)
- CNC 立式加工中心機 (400 x 800mm 盤)
- CNC 立式加工中心機 (500 x 1000mm 盤)
- CNC 四軸車銑複合加工機
- CNC 七軸車銑複合加工機
- CNC 九軸車銑複合加工機
- 立式銑床 (2馬力)
- 立式銑床 (1.5馬力)
- CNC 自動車床
- 手動車床
- 無心磨床
- 外圓磨床
- 桌上型內外圓磨床
- CNC 平面磨床
- 手動平面磨床
- 三軸自動平面磨床
- 自動內孔磨床
- CNC 三軸外圓磨床
- CNC 五軸外圓磨床
- CNC 雙軸內孔磨床



Copyright © Gin Tech Precision Co., Ltd. All Rights Reserved

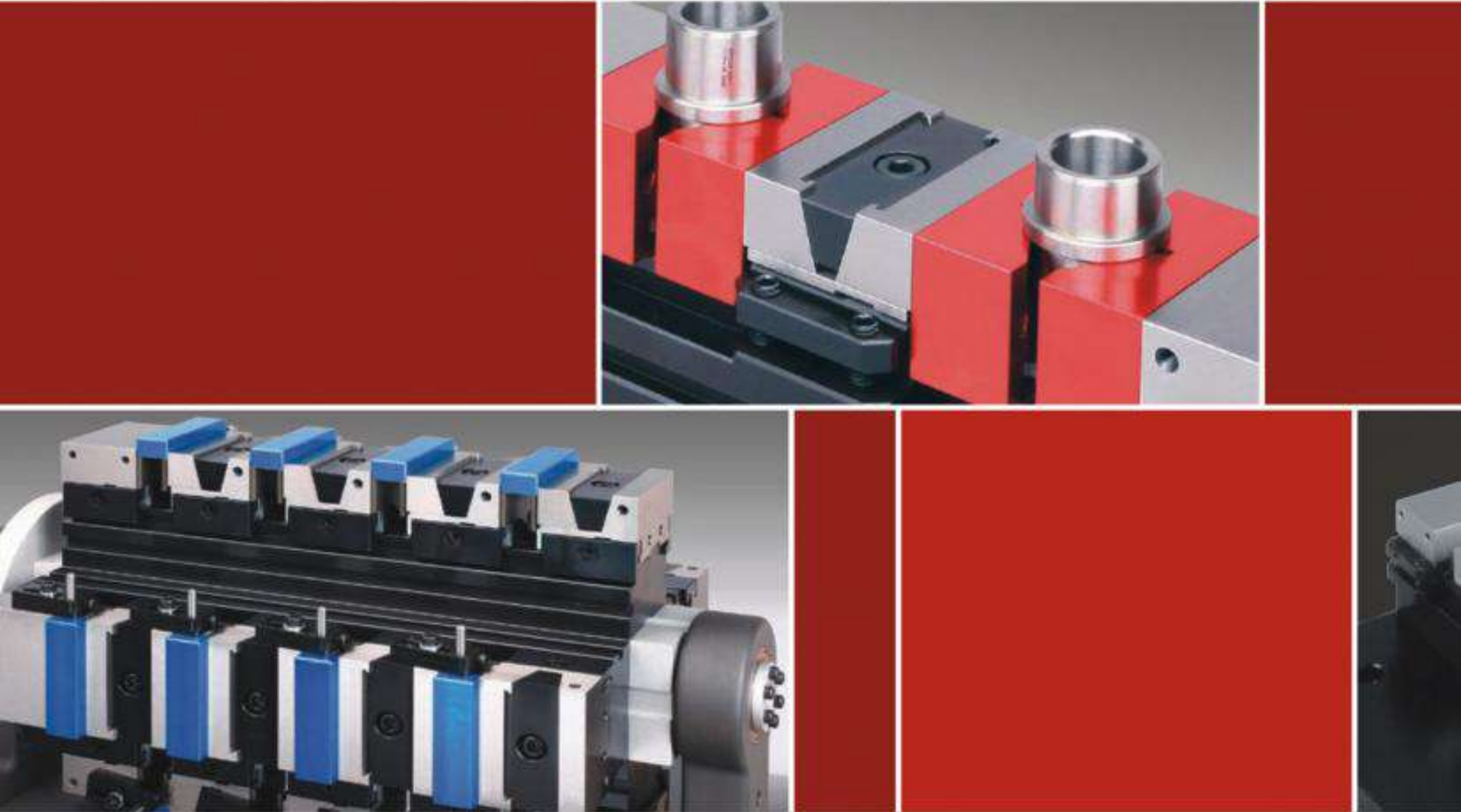

Gin Tech reserves right to amend the product content without prior notice

**精展精密科技股份有限公司(總公司)
GIN TECH PRECISION CO., LTD.**

台灣238新北市樹林區保安街一段341巷7號
Address: No 7, Lane 341, Sec. 1, Bau An Street, Shu lin Dist.,
23841, New Taipei City, Taiwan
TEL: 886-2-2681-8596 (Rep.)  Sales@ginchan.com.tw
FAX: 886-2-2681-8516  www.gin-chan.com

**東莞美商精展機械五金有限公司
東莞市精展機械五金有限公司
GIN CHAN MACHINERY & HARDWARE CO., LTD.(DONGGUAN)**

廣東省東莞市大朗鎮石厦村金沙崗二路27號
TEL : 86-769-8318-5858 (Rep.)
FAX: 86-769-8318-5838/8313-5003
 www.ginchan.com.cn  sales@ginchan.com.cn



Scan Now!

